

Test



**Quality and Service
Worldwide**



TEST 20

TYPE SMK

CONNECTION THREAD M 16 X 2

TEST

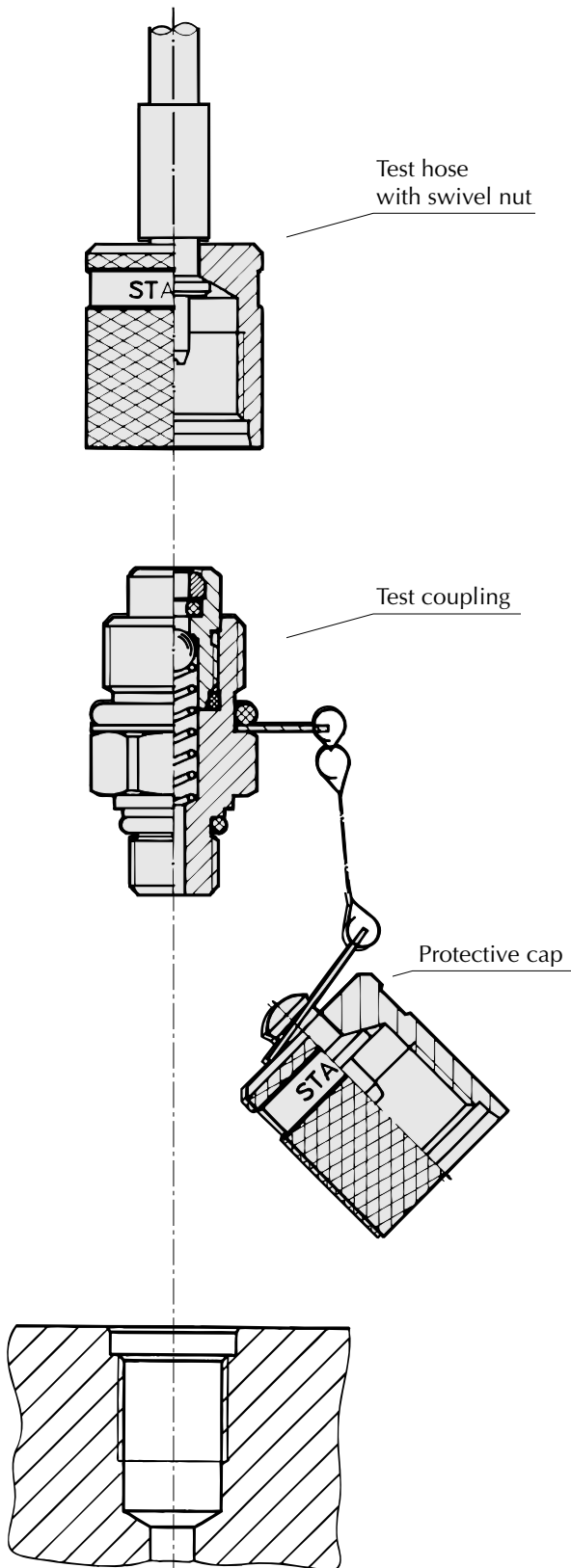

FAST COUPLING FOR:

- Monitoring and control of pressure
- Venting
- Sampling

ADVANTAGES:

- Test system at working pressure
- Connection is leakproof before **ball check** is open
- Simple connection to measurement, control and switching devices
- Self locking metal protective cap
- Minimizes introduction of contamination into hydraulic systems

WORKING PRESSURE:

- Max. working pressure 9000 Psi (630 bar)
For SMK style G, K and S the recommended working pressure of fitting manufacturer should be noted
- Connection under pressure up to 5800 Psi (400 bar) max.

MATERIALS:

- Metal parts: Steel, Stainless Steel on request
- Ball: Stainless Steel
- Seals:
 - P = NBR-BUNA Temperature range – 4°F to +195°F
(– 20° C to +90° C)
 - V = FPM-VITON Temperature range – 4°F to +392°F
(– 20° C to +200° C)
 - E = EPDM Ethylene Propylene (for Brake Fluid)
Temperature range – 40°F to +302°F
(– 40° C to + 150° C)
- Hose: Polyamide Temperature range –31°F to +212°F
(–35° C to +100° C)

MEDIA:

- Suitable for hydraulic oils and other mineral oil based fluids (Check compatibility of seal material)
- For use with other liquid media please consult STAUFF for availability of alternate seals

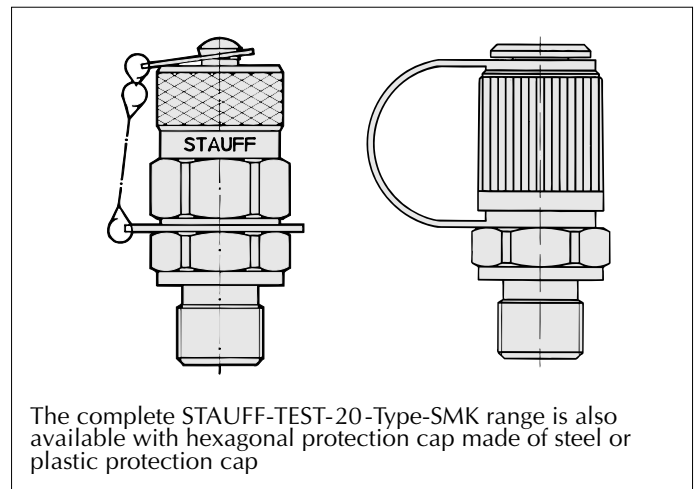

3/00

TEST COUPLING WITH PROTECTIVE CAP SMK (formerly TCM)

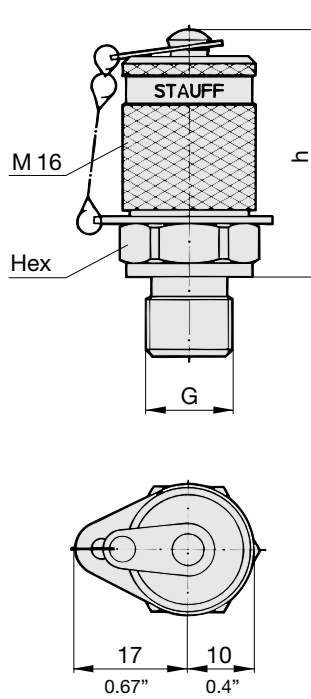
	Thread G	h		Hex		Order No.		Seal Type (see below)
		mm	in	mm	in	NBR (BUNA)	FPM (VITON)	
M8 x 1	37	1.46	0.67	17		SMK 20 – M8 x 1 – PA	SMK 20 – M8 x 1 – VA	O-Ring Type A
M10 x 1	37	1.46	0.67	17		SMK 20 – M10 x 1 – PA	SMK 20 – M10 x 1 – VA	O-Ring Type A
M12 x 1.5	37	1.46	0.67	17		SMK 20 – M12 x 1.5 – PC	SMK 20 – M12 x 1.5 – VC	O-Ring Type C
M14 x 1.5	37	1.46	0.75	19		SMK 20 – M14 x 1.5 – PB	SMK 20 – M14 x 1.5 – VB	Metal joint Type B
M16 x 1.5	37	1.46	0.87	22		SMK 20 – M16 x 1.5 – PB	SMK 20 – M16 x 1.5 – VB	Metal joint Type B
G 1/8	39	1.54	0.67	17		SMK 20 – G 1/8 – PC	SMK 20 – G 1/8 – VC	O-Ring Type C
G 1/4	37	1.46	0.75	19		SMK 20 – G 1/4 – PB	SMK 20 – G 1/4 – VB	Metal joint Type B
G 1/4	37	1.46	0.75	19		SMK 20 – G 1/4 – PC	SMK 20 – G 1/4 – VC	O-Ring Type C
G 3/8	37	1.46	0.87	22		SMK 20 – G 3/8 – PB	SMK 20 – G 3/8 – VB	Metal joint Type B
R 1/8 taper	37	1.46	0.67	17		SMK 20 – R 1/8 K-PD	SMK 20 – R 1/8 K-VD	Taper Type D
R 1/4 taper	36	1.42	0.67	17		SMK 20 – R 1/4 K-PD	SMK 20 – R 1/4 K-VD	Taper Type D
1/8 NPT	36	1.42	0.67	17		SMK 20 – 1/8 NPT-PD	SMK 20 – 1/8 NPT-VD	Taper Type D
1/4 NPT	35	1.38	0.67	17		SMK 20 – 1/4 NPT-PD	SMK 20 – 1/4 NPT-VD	Taper Type D
5/16 – 24 UNF	38	1.50	0.67	17		SMK 20 – 5/16 UNF-PE	SMK 20 – 5/16 UNF-VE	O-Ring Type E
7/16 – 20 UNF	38	1.50	0.67	17		SMK 20 – 7/16 UNF-PE	SMK 20 – 7/16 UNF-VE	O-Ring Type E
1/2 – 20 UNF	38	1.50	0.67	17		SMK 20 – 1/2 UNF-PE	SMK 20 – 1/2 UNF-VE	O-Ring Type E
9/16 – 18 UNF	37	1.46	0.75	19		SMK 20 – 9/16 UNF-PE	SMK 20 – 9/16 UNF-VE	O-Ring Type E

Other port connections and seals on request.

PORT CONNECTIONS AND SEALS

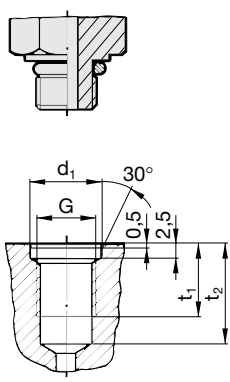
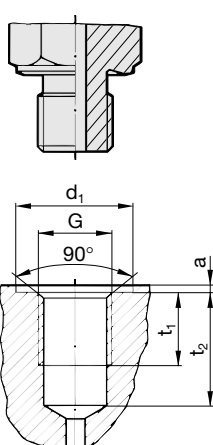
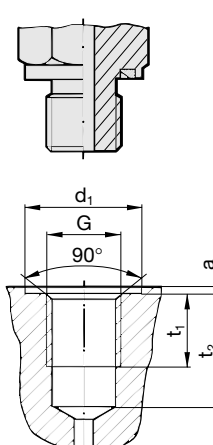
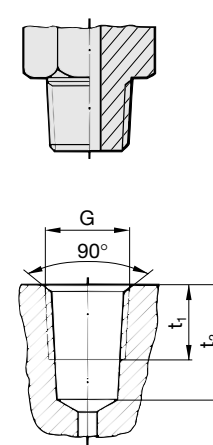
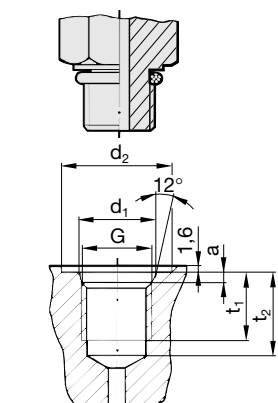
Type A				Type B					Type C					Type D			Type E						
																							
G	d ₁	t ₁	t ₂	G	d ₁	t ₁	t ₂	a	G	d ₁	t ₁	t ₂	a	G	t ₁	t ₂	G	d ₁	d ₂	t ₁	t ₂	a	
	mm	mm	mm		mm	mm	mm	mm		mm	mm	mm	mm		mm	mm	mm		mm	mm	mm	mm	mm
	in	in	in		in	in	in	in		in	in	in	in		in	in	in		in	in	in	in	in
M8 x 1	9,5 + 0,1	11	15,5	M14 x 1,5	20	12	18,5	1,5	M12 x 1,5	18	12	18,5	1,5	R 1/8 taper	5,5	9,5	5/16 – 24 UNF	9,1	17	10	12	1,9	
	0.37	0.43	0.61		0.79	0.47	0.73	0.06		0.71	0.47	0.73	0.06		0.22	0.37		0.36	0.67	0.39	0.47	0.07	
M10 x 1	11,5 + 0,1	12	16,5	M16 x 1,5	22	12	18,5	1,5	G 1/8	15	8	13	1,0	R 1/4 taper	8,5	13,5	7/16 – 20 UNF	12,4	21	11,5	14	2,4	
	0.45	0.47	0.65		0.87	0.47	0.73	0.06		0.59	0.31	0.51	0.04		0.33	0.53		0.49	0.83	0.45	0.55	0.09	
				G 1/4	19	12	18,5	1,5	G 1/4	19	12	18,5	1,5	1/8 NPT	6,9	11,6	1/2 – 20 UNF	14	23	11,5	14	2,4	
					0.75	0.47	0.73	0.06		0.75	0.47	0.73	0.06		0.27	0.46		0.55	0.91	0.45	0.55	0.09	
				G 3/8	23	12	18,5	2						1/4 NPT	10	16,4	9/16 – 18 UNF	15,6	25	12,7	15,5	2,5	
					0.91	0.47	0.73	0.08							0.39	0.65		0.61	0.98	0.50	0.61	0.10	

3/00

TEST 20

TYPE SMK

CONNECTION THREAD M 16 X 2

TEST COUPLING SMK (COMPRESSION RING FITTINGS ACC. TO DIN 2353)

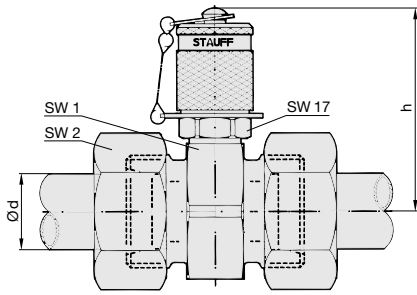

Type G Test coupling complete with straight fitting

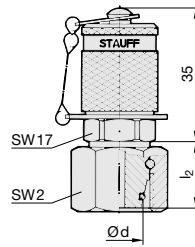

Type K Test coupling for 24° cone fittings

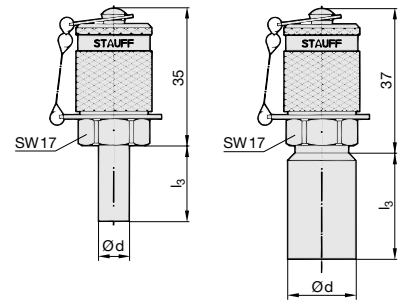

Type S Test coupling for compression ring assembly (not to be used for new constructions)

Series	PN	Pipe Ød	I ₂		I ₃		h		SW 1		SW 2		Order No.*		
			mm	in	mm	in	mm	in	mm	in	mm	in	Type G	Type K	Type S
L	315	6	15,5	0.61	20	0.79	49	1.93	24	0.94	14	0.55	SMK 20 – 6L-PG	SMK 20 – 6L-PK	SMK 20 – 6-PS
		8	15,5	0.61	20	0.79	49	1.93	24	0.94	17	0.67	SMK 20 – 8L-PG	SMK 20 – 8L-PK	SMK 20 – 8-PS
		10	16,5	0.65	22	0.87	49	1.93	24	0.94	19	0.75	SMK 20 – 10L-PG	SMK 20 – 10L-PK	SMK 20 – 10-PS
		12	17,5	0.69	22	0.87	50,5	1.99	27	1.06	22	0.87	SMK 20 – 12L-PG	SMK 20 – 12L-PK	SMK 20 – 12-PS
		15	21	0.83	25	0.98	52	2.05	30	1.18	27	1.06	SMK 20 – 15L-PG	SMK 20 – 15L-PK	SMK 20 – 15-PS
		18	19,5	0.77	28	1.10	53	2.09	32	1.26	32	1.26	SMK 20 – 18L-PG	SMK 20 – 18L-PK	SMK 20 – 18-PS
	160	22	20,5	0.81	30	1.18	55	2.17	36	1.42	36	1.42	SMK 20 – 22L-PG	SMK 20 – 22L-PK	SMK 20 – 22-PS
		28	25	0.98	32	1.26	57,5	2.26	41	1.61	41	1.61	SMK 20 – 28L-PG	SMK 20 – 28L-PK	SMK 20 – 28-PS
		35	30	1.18	42	1.65	60	2.36	46	1.81	50	1.97	SMK 20 – 35L-PG	SMK 20 – 35L-PK	SMK 20 – 35-PS
		42	31	1.22	45	1.77	64,5	2.54	55	2.17	60	2.36	SMK 20 – 42L-PG	SMK 20 – 42L-PK	SMK 20 – 42-PS
S	630	6	14,5	0.57	20	0.79	49	1.93	24	0.94	17	0.67	SMK 20 – 6S-PG	SMK 20 – 6S-PK	SMK 20 – 6-PS
		8	16,5	0.65	20	0.79	49	1.93	24	0.94	19	0.75	SMK 20 – 8S-PG	SMK 20 – 8S-PK	SMK 20 – 8-PS
		10	16,5	0.65	22	0.87	49	1.93	24	0.94	22	0.87	SMK 20 – 10S-PG	SMK 20 – 10S-PK	SMK 20 – 10-PS
		12	17,5	0.69	22	0.87	49	1.93	24	0.94	24	0.94	SMK 20 – 12S-PG	SMK 20 – 12S-PK	SMK 20 – 12-PS
		14	19,5	0.77	22	0.87	50,5	1.99	27	1.06	27	1.06	SMK 20 – 14S-PG	SMK 20 – 14S-PK	SMK 20 – 14-PS
	400	16	18	0.71	28	1.10	52	2.05	30	1.18	30	1.18	SMK 20 – 16S-PG	SMK 20 – 16S-PK	SMK 20 – 16-PS
		20	24	0.94	30	1.18	55	2.17	36	1.42	36	1.42	SMK 20 – 20S-PG	SMK 20 – 20S-PK	SMK 20 – 20-PS
		25	26	1.02	36	1.42	57,5	2.26	41	1.61	46	1.81	SMK 20 – 25S-PG	SMK 20 – 25S-PK	SMK 20 – 25-PS
		30	30	1.18	41	1.61	60	2.36	46	1.81	50	1.97	SMK 20 – 30S-PG	SMK 20 – 30S-PK	SMK 20 – 30-PS
		315	38	1.34	48	1.89	64,5	2.54	55	2.17	60	2.36	SMK 20 – 38S-PG	SMK 20 – 38S-PK	SMK 20 – 38-PS

* For ordering VITON seals please replace "P" with "V"
 * For EPDM seals replace "P" with "E"

TEST COUPLING SMK – JIC CONNECTION

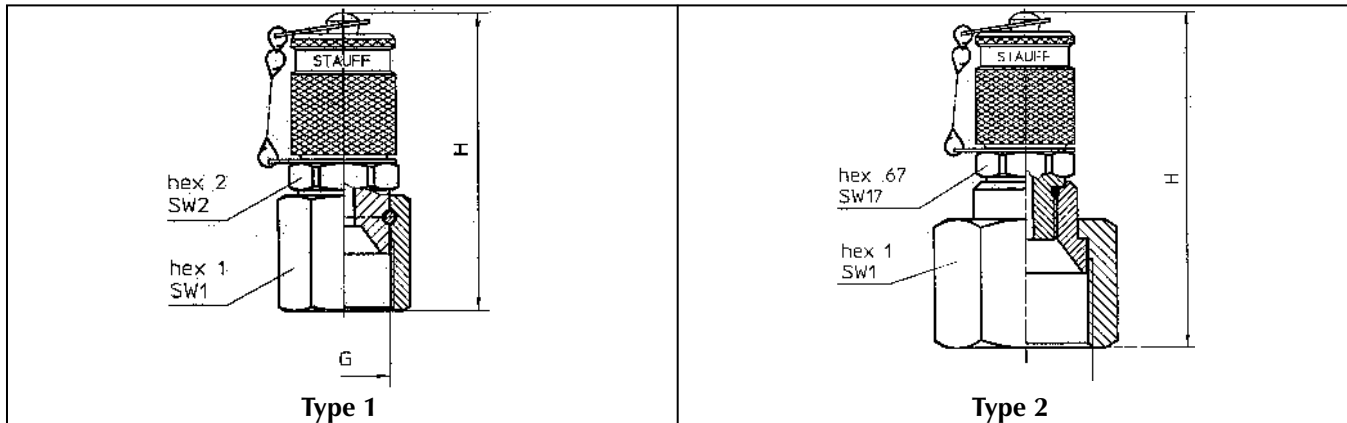

Pipe Size inch	JIC Size	G UNF	H		hex SW		Type	Order No.
			mm	inch	1	2		
1/4"	- 4	7/16" - 20	52	2.047	17	17	1	SMK20-JIC1/4-VK
5/16"	- 5	1/2" - 20	53	2.087	17	17	1	SMK20-JIC5/16-VK
3/8"	- 6	9/16" - 18	55	2.165	19	17	1	SMK20-JIC3/8-VK
1/2"	- 8	3/4" - 16	56	2.205	22	19	1	SMK20-JIC1/2-VK
5/8"	- 10	7/8" - 14	59	2.323	27	22	1	SMK20-JIC5/8-VK
3/4"	- 12	1-1/16" - 12	70	2.756	32		2	SMK20-JIC3/4-VK
1"	- 16	1-5/16" - 12	69	2.716	38		2	SMK20-JIC1-VK
1 1/4"	- 20	1-5/8" - 12	72	2.835	50		2	SMK20-JIC1-1/4-VK
1 1/2"	- 24	1-7/8" - 12	75	2.953	60		2	SMK20-JIC1-1/2-VK

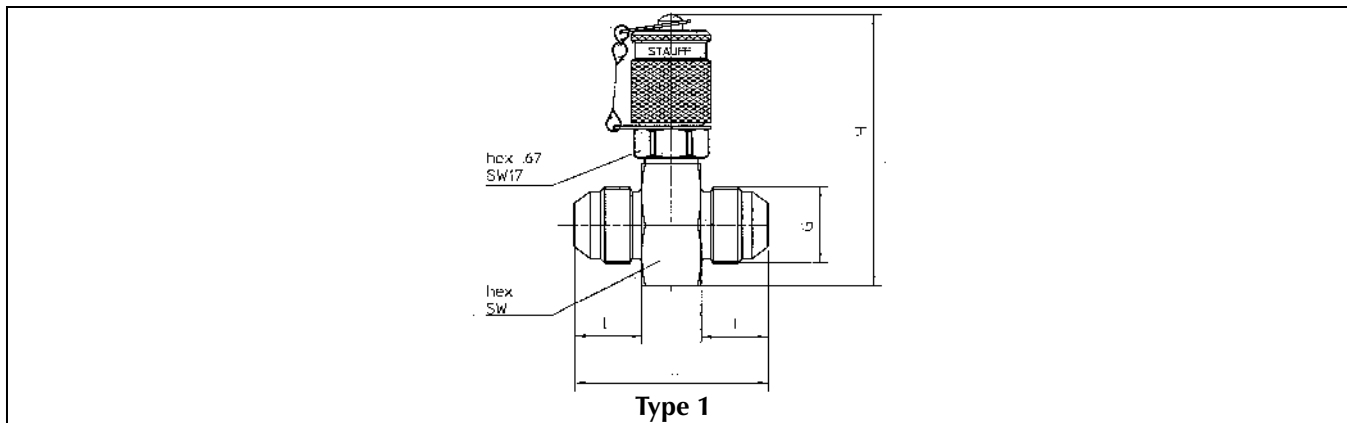

Pipe Nenngröße inch	JIC Size	G UNF	H		hex SW	L	I	Order No.
			mm	inch				
1/4"	- 4	7/16" - 20	61	2.401	24	43	14	SMK20-JIC1/4-VG
5/16"	- 5	1/2" - 20	61	2.401	24	43	14	SMK20-JIC5/16-VG
3/8"	- 6	9/16" - 18	61	2.401	24	43.2	14.1	SMK20-JIC3/8-VG
1/2"	- 8	3/4" - 16	67	2.638	30	48.4	16.7	SMK20-JIC1/2-VG
5/8"	- 10	7/8" - 14	67	2.638	30	53.6	19.3	SMK20-JIC5/8-VG
3/4"	- 12	1-1/16" - 12	73	2.874	36	58.8	21.9	SMK20-JIC3/4-VG
1"	- 16	1-5/16" - 12	78	3.071	41	61.2	23.1	SMK20-JIC1-VG
1 1/4"	- 20	1-5/8" - 12	83	3.268	46	65.6	24.3	SMK20-JIC1-1/4-VG
1 1/2"	- 24	1-7/8" - 12	92	3.622	55	72	27.5	SMK20-JIC1-1/2-VG

3/00 * For EPDM seals replace "P" with "E"

TEST HOSE SMS (formerly HFF)(for gaseous media Specify Type SGS)

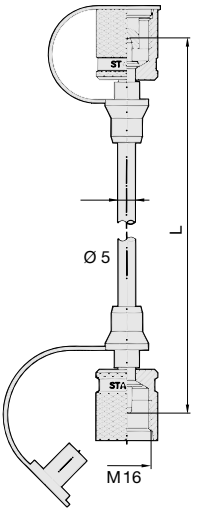
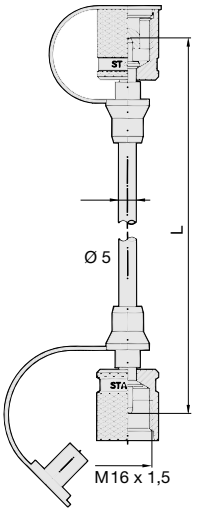
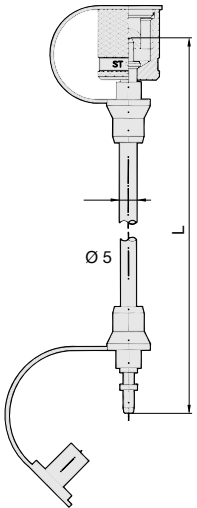
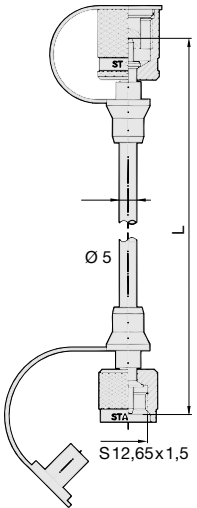
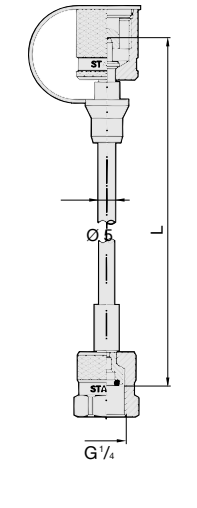
<p>Max. working pressure 5800 Psi (400 bar)</p> <p>Test hose: Nominal bore 0.08" (2 mm)</p> <p>Minimum bending radius 0.75" (20 mm)</p> <p>Nominal bore 0.16" 4 mm also available</p> <p>Pressure/t^o factor: to 0°C 122 % at 30°C 110 % at 50°C 100 % at 80°C 86 % at 100°C 77 %</p> <p>Hose construction: Hose-core and -cover PA</p> <p>Reinforcement: Synthetic fibre</p> <p>Bursting pressure: 15,950 Psi (1100 bar)</p>	<p>Stauff-Test 20/20</p>  <p>STAUFF-TEST 20</p>	<p>Stauff-Test 15/20</p>  <p>STAUFF-TEST 15</p>	<p>Stauff-Test 10/20</p>  <p>STAUFF-TEST 10</p>	<p>Stauff-Test 12/20²⁾</p>  <p>STAUFF-TEST 12</p>	<p>Stauff-Test 20/G^{1/4}</p>  <p>GAUGE ADAPTOR</p>	
	Length L ¹⁾	Order No.				
	12"	SMS-20 – 012-A	SMS-15/20 – 012-A	SMS-10/20 – 012-A	SMS-12/20 – 012-A	SMS-20/M ^{1/4} -P-OR – 012-A
	24"	SMS-20 – 024-A	SMS-15/20 – 024-A	SMS-10/20 – 024-A	SMS-12/20 – 024-A	SMS-20/M ^{1/4} -P-OR – 024-A
	36"	SMS-20 – 036-A	SMS-15/20 – 036-A	SMS-10/20 – 036-A	SMS-12/20 – 036-A	SMS-20/M ^{1/4} -P-OR – 036-A
	48"	SMS-20 – 048-A	SMS-15/20 – 048-A	SMS-10/20 – 048-A	SMS-12/20 – 048-A	SMS-20/M ^{1/4} -P-OR – 048-A
	60"	SMS-20 – 060-A	SMS-15/20 – 060-A	SMS-10/20 – 060-A	SMS-12/20 – 060-A	SMS-20/M ^{1/4} -P-OR – 060-A
	72"	SMS-20 – 072-A	SMS-15/20 – 072-A	SMS-10/20 – 072-A	SMS-12/20 – 072-A	SMS-20/M ^{1/4} -P-OR – 072-A
	96"	SMS-20 – 096-A	SMS-15/20 – 096-A	SMS-10/20 – 096-A	SMS-12/20 – 096-A	SMS-20/M ^{1/4} -P-OR – 096-A
	120"	SMS-20 – 120-A	SMS-15/20 – 120-A	SMS-10/20 – 120-A	SMS-12/20 – 120-A	SMS-20/M ^{1/4} -P-OR – 120-A
Custom lengths available on request						
¹⁾ Bending protection and other lengths on request		²⁾ Special thread: buttress thread S 12,65 x 1,5		³⁾ Gauge adaptor 1/4 NPT, G 1/2 and 1/2 NPT on request		

TRANSITION ADAPTOR SAD

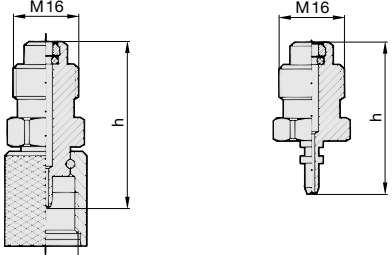
 <p>Type A</p> <p>Type B</p>	G	h	Type	Order No.		
		in		mm	NBR (BUNA)	FPM (VITON)
	M16 x 1,5	1.53	39	A	SAD 20/15-P	SAD 20/15-V
		1.45	37	B	SAD 20/10-P	SAD 20/10-V
	plug in	1.53	39	A	SAD 20/12-P	SAD 20/12-V
S12 ¹⁾	¹⁾ Special thread: buttress thread S 12,65 x 1,5					

BULKHEAD SSK (for gaseous medium Type SSK)

	<table border="1"> <thead> <tr> <th rowspan="2">G</th> <th colspan="2">h</th> <th rowspan="2">Type</th> <th colspan="2">Order No.</th> </tr> <tr> <th>mm</th> <th>in</th> <th>NBR (BUNA)</th> <th>FPM (VITON)</th> </tr> </thead> <tbody> <tr> <td>M16</td> <td>72</td> <td>2.8</td> <td>A</td> <td>SSK 20-P</td> <td>SSK 20-V</td> </tr> <tr> <td>M16 x 1,5¹⁾</td> <td>72</td> <td>2.8</td> <td>B</td> <td>SSK 20/08 S-P</td> <td>SSK 20/08 S-V</td> </tr> <tr> <td>M18 x 1,5¹⁾</td> <td>72</td> <td>2.8</td> <td>B</td> <td>SSK 20/12 L-P</td> <td>SSK 20/12 L-V</td> </tr> <tr> <td>7/16 UNF (-4 JIC)</td> <td>63</td> <td>2.48</td> <td>A</td> <td>N/A</td> <td>SSK20-7/16 JIC-MV</td> </tr> </tbody> </table>	G	h		Type	Order No.		mm	in	NBR (BUNA)	FPM (VITON)	M16	72	2.8	A	SSK 20-P	SSK 20-V	M16 x 1,5 ¹⁾	72	2.8	B	SSK 20/08 S-P	SSK 20/08 S-V	M18 x 1,5 ¹⁾	72	2.8	B	SSK 20/12 L-P	SSK 20/12 L-V	7/16 UNF (-4 JIC)	63	2.48	A	N/A	SSK20-7/16 JIC-MV
			G	h		Type	Order No.																												
mm	in	NBR (BUNA)		FPM (VITON)																															
M16	72	2.8	A	SSK 20-P	SSK 20-V																														
M16 x 1,5 ¹⁾	72	2.8	B	SSK 20/08 S-P	SSK 20/08 S-V																														
M18 x 1,5 ¹⁾	72	2.8	B	SSK 20/12 L-P	SSK 20/12 L-V																														
7/16 UNF (-4 JIC)	63	2.48	A	N/A	SSK20-7/16 JIC-MV																														
<p>¹⁾ Compression ring assembly 8 S/12 L acc. to DIN 2353</p>																																			

GAUGE ADAPTOR SMA

	<table border="1"> <thead> <tr> <th rowspan="2">G</th> <th colspan="2">h</th> <th rowspan="2">SW</th> <th colspan="2">Order No.</th> </tr> <tr> <th>mm</th> <th>in</th> <th>NBR (BUNA)</th> <th>FPM (VITON)</th> </tr> </thead> <tbody> <tr> <td>G 1/4</td> <td>54</td> <td>2.12</td> <td>19 .75</td> <td>SMA 20 - G 1/4 - P-OR</td> <td>SMA 20 - G 1/4 - V-OR</td> </tr> <tr> <td>G 1/2</td> <td>64</td> <td>2.52</td> <td>27 1.06</td> <td>SMA 20 - G 1/2 - P-OR</td> <td>SMA 20 - G 1/2 - V-OR</td> </tr> <tr> <td>1/4 NPT</td> <td>54</td> <td>2.12</td> <td>19 .75</td> <td>SMA 20 - 1/4 NPT-P</td> <td>SMA 20 - 1/4 NPT-V</td> </tr> <tr> <td>1/2 NPT</td> <td>64</td> <td>2.52</td> <td>27 1.06</td> <td>SMA 20 - 1/2 NPT-P</td> <td>SMA 20 - 1/2 NPT-V</td> </tr> </tbody> </table>	G	h		SW	Order No.		mm	in	NBR (BUNA)	FPM (VITON)	G 1/4	54	2.12	19 .75	SMA 20 - G 1/4 - P-OR	SMA 20 - G 1/4 - V-OR	G 1/2	64	2.52	27 1.06	SMA 20 - G 1/2 - P-OR	SMA 20 - G 1/2 - V-OR	1/4 NPT	54	2.12	19 .75	SMA 20 - 1/4 NPT-P	SMA 20 - 1/4 NPT-V	1/2 NPT	64	2.52	27 1.06	SMA 20 - 1/2 NPT-P	SMA 20 - 1/2 NPT-V
			G	h		SW	Order No.																												
mm	in	NBR (BUNA)		FPM (VITON)																															
G 1/4	54	2.12	19 .75	SMA 20 - G 1/4 - P-OR	SMA 20 - G 1/4 - V-OR																														
G 1/2	64	2.52	27 1.06	SMA 20 - G 1/2 - P-OR	SMA 20 - G 1/2 - V-OR																														
1/4 NPT	54	2.12	19 .75	SMA 20 - 1/4 NPT-P	SMA 20 - 1/4 NPT-V																														
1/2 NPT	64	2.52	27 1.06	SMA 20 - 1/2 NPT-P	SMA 20 - 1/2 NPT-V																														
<p>Damping element on request</p>																																			

DIRECT GAUGE ADAPTOR SMD

	<table border="1"> <thead> <tr> <th rowspan="2">G</th> <th colspan="2">h</th> <th rowspan="2">SW</th> <th colspan="2">Order No.</th> </tr> <tr> <th>mm</th> <th>in</th> <th>NBR (BUNA)</th> <th>FPM (VITON)</th> </tr> </thead> <tbody> <tr> <td>G 1/4</td> <td>41</td> <td>1.61</td> <td>19 .75</td> <td>SMD 20 - G 1/4 - P-OR</td> <td>SMD 20 - G 1/4 - V-OR</td> </tr> <tr> <td>G 1/2</td> <td>51</td> <td>2.0</td> <td>27 1.06</td> <td>SMD 20 - G 1/2 - P-OR</td> <td>SMD 20 - G 1/2 - V-OR</td> </tr> <tr> <td>1/4 NPT</td> <td>41</td> <td>1.61</td> <td>19 .75</td> <td>SMD 20 - 1/4 NPT-P</td> <td>SMD 20 - 1/4 NPT-V</td> </tr> <tr> <td>1/2 NPT</td> <td>51</td> <td>2.0</td> <td>27 1.06</td> <td>SMD 20 - 1/2 NPT-P</td> <td>SMD 20 - 1/2 NPT-V</td> </tr> </tbody> </table>	G	h		SW	Order No.		mm	in	NBR (BUNA)	FPM (VITON)	G 1/4	41	1.61	19 .75	SMD 20 - G 1/4 - P-OR	SMD 20 - G 1/4 - V-OR	G 1/2	51	2.0	27 1.06	SMD 20 - G 1/2 - P-OR	SMD 20 - G 1/2 - V-OR	1/4 NPT	41	1.61	19 .75	SMD 20 - 1/4 NPT-P	SMD 20 - 1/4 NPT-V	1/2 NPT	51	2.0	27 1.06	SMD 20 - 1/2 NPT-P	SMD 20 - 1/2 NPT-V
			G	h		SW	Order No.																												
mm	in	NBR (BUNA)		FPM (VITON)																															
G 1/4	41	1.61	19 .75	SMD 20 - G 1/4 - P-OR	SMD 20 - G 1/4 - V-OR																														
G 1/2	51	2.0	27 1.06	SMD 20 - G 1/2 - P-OR	SMD 20 - G 1/2 - V-OR																														
1/4 NPT	41	1.61	19 .75	SMD 20 - 1/4 NPT-P	SMD 20 - 1/4 NPT-V																														
1/2 NPT	51	2.0	27 1.06	SMD 20 - 1/2 NPT-P	SMD 20 - 1/2 NPT-V																														
<p>Damping element on request</p>																																			

WELDING ADAPTOR SAS

	<table border="1"> <thead> <tr> <th rowspan="2">Coupling thread G</th> <th colspan="2">h</th> <th rowspan="2">Ød</th> <th rowspan="2">Order No.</th> </tr> <tr> <th>mm</th> <th>in</th> <th>mm</th> <th>in</th> </tr> </thead> <tbody> <tr> <td>M10 x 1</td> <td>25</td> <td>.98</td> <td>20 .78</td> <td>SAS - M10 x 1</td> </tr> <tr> <td>G 1/4</td> <td>30</td> <td>1.18</td> <td>22 .86</td> <td>SAS - G 1/4</td> </tr> </tbody> </table>	Coupling thread G	h		Ød	Order No.	mm	in	mm	in	M10 x 1	25	.98	20 .78	SAS - M10 x 1	G 1/4	30	1.18	22 .86	SAS - G 1/4
			Coupling thread G	h			Ød	Order No.												
mm	in	mm		in																
M10 x 1	25	.98	20 .78	SAS - M10 x 1																
G 1/4	30	1.18	22 .86	SAS - G 1/4																
<p>Material: St 37</p>																				

THREAD ADAPTOR SRS

	<table border="1"> <thead> <tr> <th rowspan="2">Thread G</th> <th colspan="2">h</th> <th rowspan="2">SW</th> <th rowspan="2">Order No.</th> <th rowspan="2">Seal</th> </tr> <tr> <th>mm</th> <th>in</th> <th>mm</th> <th>in</th> </tr> </thead> <tbody> <tr> <td>M16 x 1,5</td> <td>8</td> <td>.31</td> <td>22 .86</td> <td>SRS 20 - M16 x 1,5-B</td> <td rowspan="4">Metal joint DIN 3852 Type B</td> </tr> <tr> <td>G 1/8</td> <td>15,5</td> <td>.61</td> <td>17 .67</td> <td>SRS 20 - G 1/8-B</td> </tr> <tr> <td>G 3/8</td> <td>10,5</td> <td>.41</td> <td>22 .86</td> <td>SRS 20 - G 3/8-B</td> </tr> <tr> <td>G 1/2</td> <td>10,5</td> <td>.41</td> <td>27 1.06</td> <td>SRS 20 - G 1/2-B</td> </tr> <tr> <td>R 1/4 taper</td> <td>13</td> <td>.51</td> <td>17 .67</td> <td>SRS 20 - R 1/4 K-D</td> <td>Port Connection Type D</td> </tr> </tbody> </table>	Thread G	h		SW	Order No.	Seal	mm	in	mm	in	M16 x 1,5	8	.31	22 .86	SRS 20 - M16 x 1,5-B	Metal joint DIN 3852 Type B	G 1/8	15,5	.61	17 .67	SRS 20 - G 1/8-B	G 3/8	10,5	.41	22 .86	SRS 20 - G 3/8-B	G 1/2	10,5	.41	27 1.06	SRS 20 - G 1/2-B	R 1/4 taper	13	.51	17 .67	SRS 20 - R 1/4 K-D	Port Connection Type D
			Thread G	h				SW	Order No.	Seal																												
mm	in	mm		in																																		
M16 x 1,5	8	.31	22 .86	SRS 20 - M16 x 1,5-B	Metal joint DIN 3852 Type B																																	
G 1/8	15,5	.61	17 .67	SRS 20 - G 1/8-B																																		
G 3/8	10,5	.41	22 .86	SRS 20 - G 3/8-B																																		
G 1/2	10,5	.41	27 1.06	SRS 20 - G 1/2-B																																		
R 1/4 taper	13	.51	17 .67	SRS 20 - R 1/4 K-D	Port Connection Type D																																	

3/00

TEST

TEST 20

TYPE SKK

CONNECTION THREAD M 16 X 2

TEST

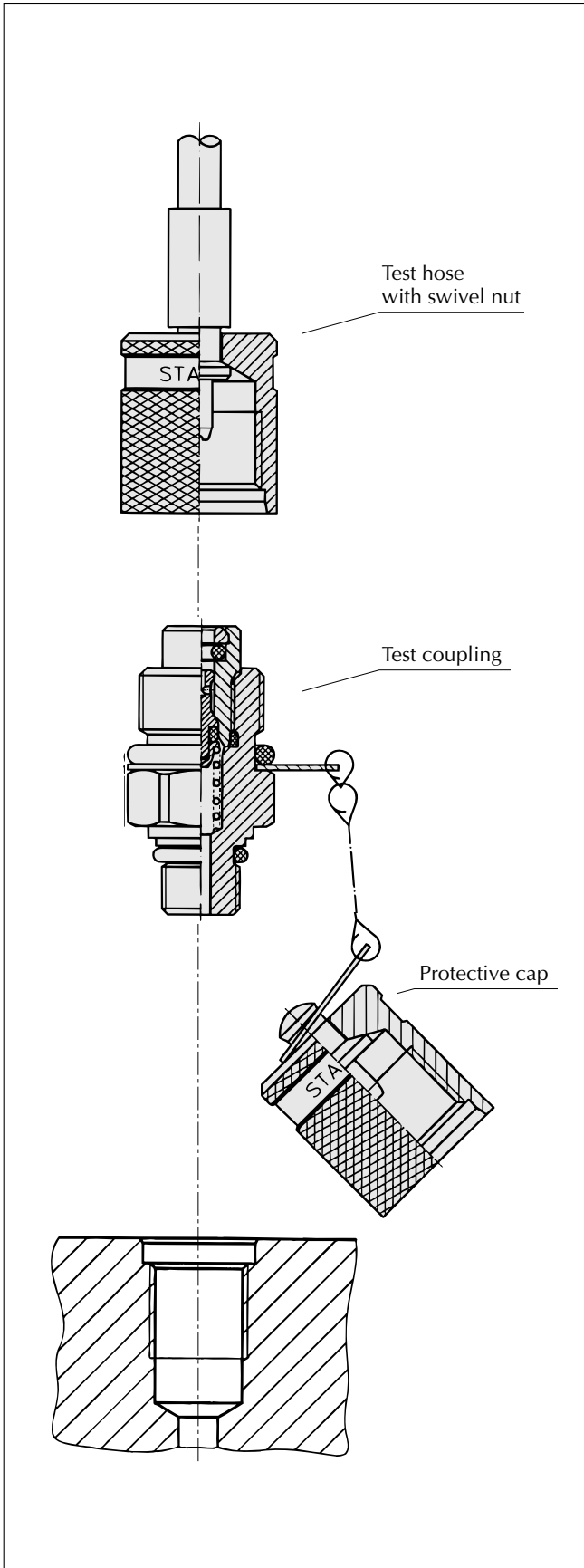

FAST COUPLING FOR:

- Monitoring and control of pressure
- Venting
- Sampling

ADVANTAGES:

- Coupling at system pressure level
- Connection is leakproof before **piston valve** is open
- Simple connection to measurement, control and switching devices
- Self locking metal protective cap
- Minimizes introduction of contamination to hydraulic systems

WORKING PRESSURE:

- Max. working pressure 9000 Psi (630 bar)
For SKK type G, K and S the recommended working pressure of fitting manufacturer should be noted
- Connection under pressure up to 5800 Psi (400 bar) max.

MATERIALS:

- Metal parts: Steel, Stainless Steel on request
- Seals:
 - P = NBR-BUNA Temperature range - 4°F to +195°F (- 20° C to +90° C)
 - V = FPM-VITON Temperature range - 4°F to +392°F (- 20° C to +200° C)
 - E = EPDM Ethylene Propylene (for Brake Fluid) Temperature range - 40°F to +302°F (- 40° C to +150° C)
- Hose: Polyamide Temperature range -31°F to +212°F (-35° C to +100° C)

MEDIA:

- Suitable for hydraulic oils and other mineral oil based fluids (Check compatibility of seal material)
- For use with other liquid or gaseous media please consult STAUFF for availability of alternate seals

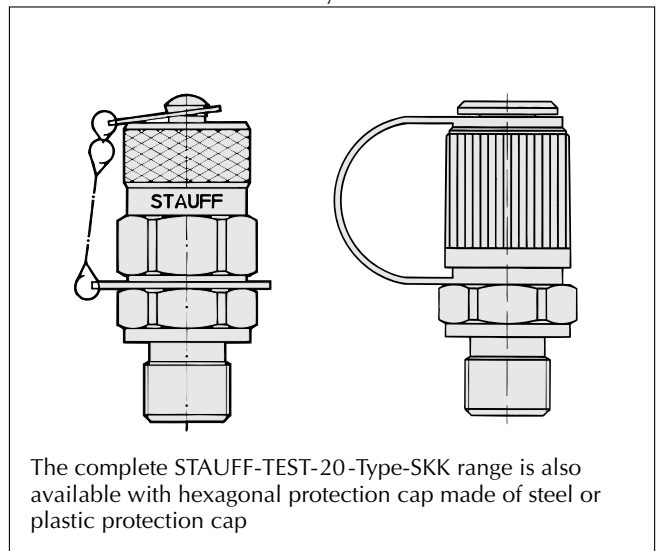

The complete STAUFF-TEST-20-Type-SKK range is also available with hexagonal protection cap made of steel or plastic protection cap

3/00

TEST COUPLING WITH PROTECTIVE CAP SKK

	Thread G	Hex		Order No.		Seal Type (see below)	
		h	mm	mm	NBR (BUNA)		FPM (VITON)
		mm	in	in			
M8 x 1	37	17	.67	SKK 20 – M8 x 1 – PA	SKK 20 – M8 x 1 – VA	O-Ring Type A	
M10 x 1	37	17	.67	SKK 20 – M10 x 1 – PA	SKK 20 – M10 x 1 – VA	O-Ring Type A	
M12 x 1,5	37	17	.67	SKK 20 – M12 x 1,5 – PC	SKK 20 – M12 x 1,5 – VC	O-Ring Type C	
M14 x 1,5	37	19	.75	SKK 20 – M14 x 1,5 – PB	SKK 20 – M14 x 1,5 – VB	Metal joint Type B	
M16 x 1,5	37	22	.87	SKK 20 – M16 x 1,5 – PB	SKK 20 – M16 x 1,5 – VB	Metal joint Type B	
G 1/8	39	17	.67	SKK 20 – G 1/8 – PC	SKK 20 – G 1/8 – VC	O-Ring Type C	
G 1/4	37	19	.75	SKK 20 – G 1/4 – PB	SKK 20 – G 1/4 – VB	Metal joint Type B	
G 1/4	37	19	.75	SKK 20 – G 1/4 – PC	SKK 20 – G 1/4 – VC	O-Ring Type C	
G 3/8	37	22	.87	SKK 20 – G 3/8 – PB	SKK 20 – G 3/8 – VB	Metal joint Type B	
R 1/8 taper	37	17	.67	SKK 20 – R 1/8 K-PD	SKK 20 – R 1/8 K-VD	Taper Type D	
R 1/4 taper	36	17	.67	SKK 20 – R 1/4 K-PD	SKK 20 – R 1/4 K-VD	Taper Type D	
1/8 NPT	36	17	.67	SKK 20 – 1/8 NPT-PD	SKK 20 – 1/8 NPT-VD	Taper Type D	
1/4 NPT	35	17	.67	SKK 20 – 1/4 NPT-PD	SKK 20 – 1/4 NPT-VD	Taper Type D	
5/16 – 24 UNF	38	17	.67	SKK 20 – 5/16 UNF-PE	SKK 20 – 5/16 UNF-VE	O-Ring Type E	
7/16 – 20 UNF	38	17	.67	SKK 20 – 7/16 UNF-PE	SKK 20 – 7/16 UNF-VE	O-Ring Type E	
1/2 – 20 UNF	38	17	.67	SKK 20 – 1/2 UNF-PE	SKK 20 – 1/2 UNF-VE	O-Ring Type E	
9/16 – 18 UNF	37	19	.75	SKK 20 – 9/16 UNF-PE	SKK 20 – 9/16 UNF-VE	O-Ring Type E	

Other port connections and seals on request.

PORT CONNECTIONS AND SEALS

Type A				Type B					Type C					Type D			Type E						
G	d ₁	t ₁	t ₂	G	d ₁	t ₁	t ₂	a	G	d ₁	t ₁	t ₂	a	G	t ₁	t ₂	G	d ₁	d ₂	t ₁	t ₂	a	
	mm	mm	mm	mm	mm	mm	mm	mm	mm	mm	mm	mm	mm	mm	mm	mm	mm	mm	mm	mm	mm	mm	mm
	in	in	in	in	in	in	in	in	in	in	in	in	in	in	in	in	in	in	in	in	in	in	in
M8 x 1	9,5 + 0,1	11	15,5	20	12	18,5	1,5		18	12	18,5	1,5		R 1/8 taper	5,5	9,5	5/16 – 24 UNF	9,1	17	10	12	1,9	
	0.37	0.43	0.61	0.79	0.47	0.73	0.06		0.71	0.47	0.73	0.06			0.22	0.37		0.36	0.67	0.39	0.47	0.07	
M10 x 1	11,5 + 0,1	12	16,5	22	12	18,5	1,5		15	8	13	1,0		R 1/4 taper	8,5	13,5	7/16 – 20 UNF	12,4	21	11,5	14	2,4	
	0.45	0.47	0.65	0.87	0.47	0.73	0.06		0.59	0.31	0.51	0.04			0.33	0.53		0.49	0.83	0.45	0.55	0.09	
														1/8 NPT	6,9	11,6	1/2 – 20 UNF	14	23	11,5	14	2,4	
															0.27	0.46		0.55	0.91	0.45	0.55	0.09	
														1/4 NPT	10	16,4	9/16 – 18 UNF	15,6	25	12,7	15,5	2,5	
															0.39	0.65		0.61	0.98	0.50	0.61	0.10	

3/00

TEST 20 TYPE SKK CONNECTION THREAD M 16 X 2

TEST COUPLING SKK (compression ring fittings acc. to DIN 2353)

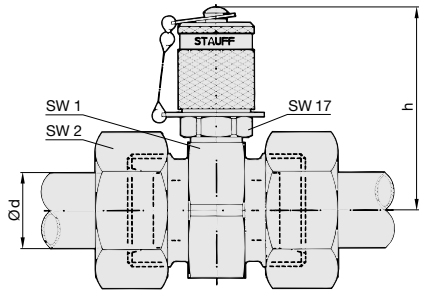

Type G Test coupling complete with straight fitting

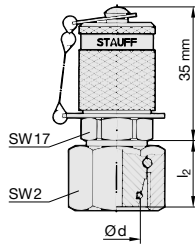

Type K Test coupling for 24° cone fittings

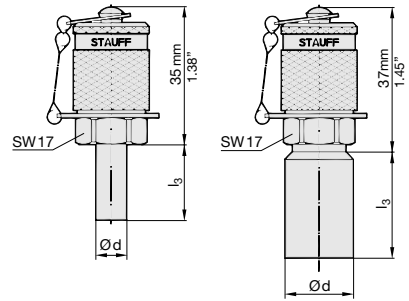

Type S Test coupling for compression ring assembly

Series	PN Psi (Bar)	Pipe Ød	l ₂		l ₃		h		SW 1		SW 2		Order No.*		
			mm	in	mm	in	mm	in	mm	in	mm	in	Type G	Type K	Type S
L	4500 (315)	6	15,5	0.61	20	0.79	49	1.93	24	0.94	14	0.55	SKK 20 – 6L-PG	SKK 20 – 6L-PK	SKK 20 – 6-PS
		8	15,5	0.61	20	0.79	49	1.93	24	0.94	17	0.67	SKK 20 – 8L-PG	SKK 20 – 8L-PK	SKK 20 – 8-PS
		10	16,5	0.65	22	0.87	49	1.93	24	0.94	19	0.75	SKK 20 – 10L-PG	SKK 20 – 10L-PK	SKK 20 – 10-PS
		12	17,5	0.69	22	0.87	50	1.97	27	1.06	22	0.87	SKK 20 – 12L-PG	SKK 20 – 12L-PK	SKK 20 – 12-PS
		15	21	0.83	25	0.98	52	2.05	30	1.18	27	1.06	SKK 20 – 15L-PG	SKK 20 – 15L-PK	SKK 20 – 15-PS
		18	19,5	0.77	28	1.10	53	2.09	32	1.26	32	1.26	SKK 20 – 18L-PG	SKK 20 – 18L-PK	SKK 20 – 18-PS
	2300 (160)	22	20,5	0.81	30	1.18	55	2.17	36	1.42	36	1.42	SKK 20 – 22L-PG	SKK 20 – 22L-PK	SKK 20 – 22-PS
		28	25	0.98	32	1.26	57,5	2.26	41	1.61	41	1.61	SKK 20 – 28L-PG	SKK 20 – 28L-PK	SKK 20 – 28-PS
		35	30	1.18	42	1.65	60	2.36	46	1.81	50	1.97	SKK 20 – 35L-PG	SKK 20 – 35L-PK	SKK 20 – 35-PS
		42	31	1.22	45	1.77	64,5	2.54	55	2.17	60	2.36	SKK 20 – 42L-PG	SKK 20 – 42L-PK	SKK 20 – 42-PS
S	9100 (630)	6	14,5	0.57	20	0.79	49	1.93	24	0.94	17	0.67	SKK 20 – 6S-PG	SKK 20 – 6S-PK	SKK 20 – 6-PS
		8	16,5	0.65	20	0.79	49	1.93	24	0.94	19	0.75	SKK 20 – 8S-PG	SKK 20 – 8S-PK	SKK 20 – 8-PS
		10	16,5	0.65	22	0.87	49	1.93	24	0.94	22	0.87	SKK 20 – 10S-PG	SKK 20 – 10S-PK	SKK 20 – 10-PS
		12	17,5	0.69	22	0.87	49	1.93	24	0.94	24	0.94	SKK 20 – 12S-PG	SKK 20 – 12S-PK	SKK 20 – 12-PS
		14	19,5	0.77	22	0.87	50,5	1.99	27	1.06	27	1.06	SKK 20 – 14S-PG	SKK 20 – 14S-PK	SKK 20 – 14-PS
	5800 (400)	16	18	0.71	28	1.10	52	2.05	30	1.18	30	1.18	SKK 20 – 16S-PG	SKK 20 – 16S-PK	SKK 20 – 16-PS
		20	24	0.94	30	1.18	55	2.17	36	1.42	36	1.42	SKK 20 – 20S-PG	SKK 20 – 20S-PK	SKK 20 – 20-PS
		25	26	1.02	36	1.42	57,5	2.26	41	1.61	46	1.81	SKK 20 – 25S-PG	SKK 20 – 25S-PK	SKK 20 – 25-PS
		30	30	1.18	41	1.61	60	2.36	46	1.81	50	1.97	SKK 20 – 30S-PG	SKK 20 – 30S-PK	SKK 20 – 30-PS
		4500 315	38	34	1.34	48	1.89	64,5	2.54	55	2.17	60	2.36	SKK 20 – 38S-PG	SKK 20 – 38S-PK

* For ordering FPM seals please replace "P" with "V"
* For EPDM seals replace "P" with "E"

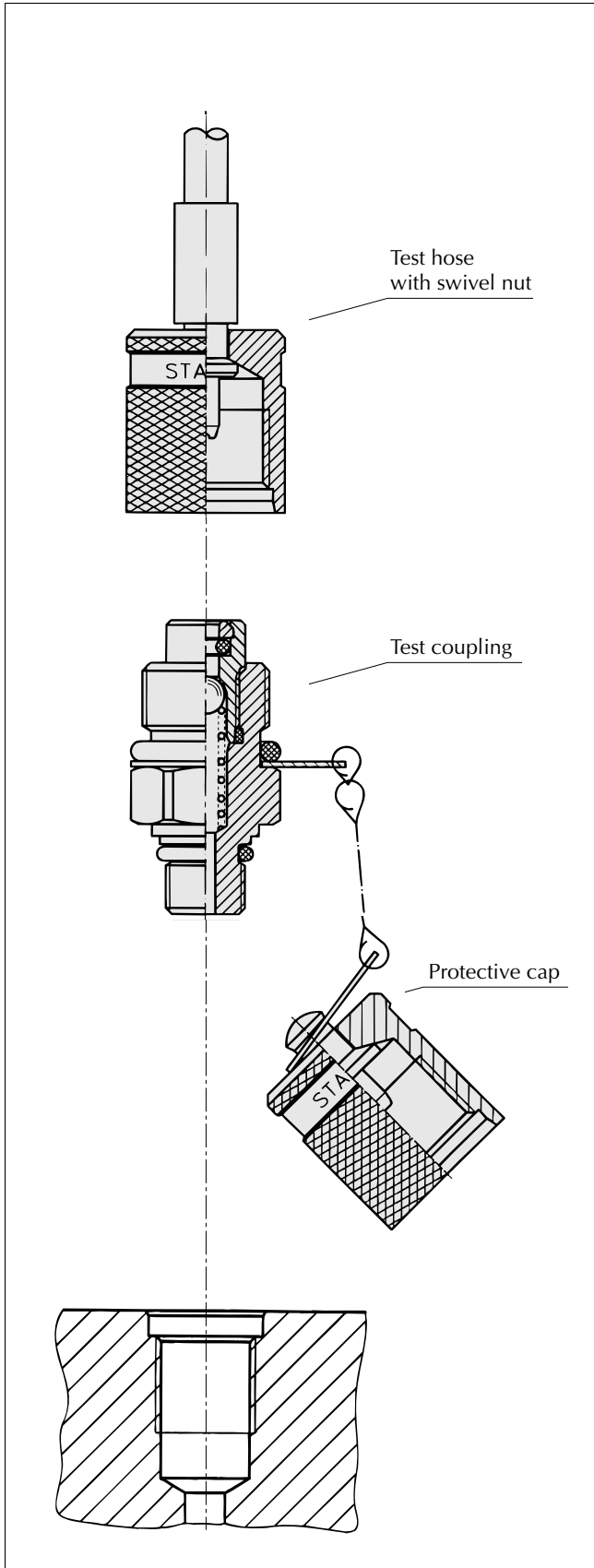

3/00 On request TEST 15 couplings are available as SKK-type

FAST COUPLING FOR:

- Monitoring and control of pressure
- Venting
- Sampling

ADVANTAGES:

- Coupling at system pressure level
- Connection is leakproof before **ball valve** is open
- Simple connection to measurement, control and switching devices
- Self locking metal protective cap

WORKING PRESSURE:

- Max. working pressure 9000 Psi (630 bar)
For SMK type G, K and S the recommended working pressure of fitting manufacturer should be noted
- Connection under pressure up to 9000 Psi (630 bar) max.

MATERIALS:

- Metal parts: Steel, Stainless Steel on request
- Ball: Stainless Steel
- Seals:
 - P = NBR-BUNA Temperature range – 4°F to +195°F
(– 20° C to +90° C)
 - V = FPM-VITON Temperature range – 4°F to +392°F
(– 20° C to +200° C)
 - E = EPDM Ethylene Propylene (for Brake Fluid)
Temperature range – 40°F to +302°F
(– 40° C to + 150° C)
- Hose: Polyamide Temperature range –31°F to +212°F
(–35° C to +100° C)

MEDIA:

- Suitable for hydraulic oils and other mineral oil based fluids (check compatibility of seal material)
- For use with other liquid media please consult STAUFF for availability of alternate seals

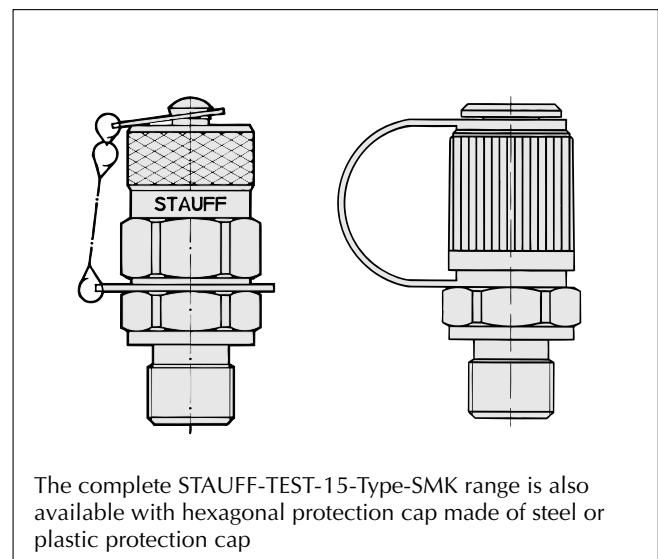

The complete STAUFF-TEST-15-Type-SMK range is also available with hexagonal protection cap made of steel or plastic protection cap

TEST 15

TYPE SMK

CONNECTION THREAD M 16 X 1,5

TEST

TEST COUPLING WITH PROTECTIVE CAP SMK (formerly TCM)

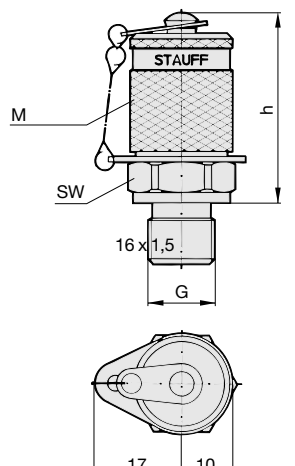
	Thread G	h		SW		Order No.		Seal
		mm	in	mm	in	NBR (BUNA)	FPM (VITON)	
M10 x 1	37 1.46	17 0.67			SMK 15 – M10 x 1 – PA	SMK 15 – M10 x 1 – VA	O-Ring Type A	
M14 x 1,5	37 1.46	19 0.75			SMK 15 – M14 x 1,5 – PB	SMK 15 – M14 x 1,5 – VB	Metal joint Type B	
M16 x 1,5	37 1.46	22 0.87			SMK 15 – M16 x 1,5 – PB	SMK 15 – M16 x 1,5 – VB	Metal joint Type B	
G 1/4	37 1.46	19 0.75			SMK 15 – G 1/4 – PB	SMK 15 – G 1/4 – VB	Metal joint Type B	
G 1/4	37 1.46	19 0.75			SMK 15 – G 1/4 – PC	SMK 15 – G 1/4 – VC	O-Ring Type C	
G 3/8	37 1.46	22 0.87			SMK 15 – G 3/8 – PB	SMK 15 – G 3/8 – VB	Metal joint Type B	
R 1/4 taper	36 1.42	17 0.67			SMK 15 – R 1/4 K-PD	SMK 15 – R 1/4 K-VD	Taper Type D	
1/4 NPT	35 1.38	17 0.67			SMK 15 – 1/4 NPT-PD	SMK 15 – 1/4 NPT-VD	Taper Type D	
9/16 – 18 UNF	37 1.46	19 0.75			SMK 15 – 9/16 UNF-PE	SMK 15 – 9/16 UNF-VE	O-Ring Type E	

Other port connections and seals on request.

THREAD ADAPTOR SRS

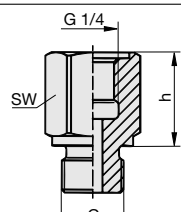
	Thread G	h		SW		Order No.	Seal
		mm	in	mm	in		
		M18 x 1,5	24 0.94	24 0.94			
M20 x 1,5	10,5 0.41	27 1.06			SRS 15 – M20 x 1,5-B		
G 3/8	24 0.94	22 0.87			SRS 15 – G 3/8-B		
G 1/2	10,5 0.41	27 1.06			SRS 15 – G 1/2-B		

PORT CONNECTIONS AND SEALS

Type A				Type B					Type C					Type D			Type E							
G	d ₁	t ₁	t ₂	G	d ₁	t ₁	t ₂	a	G	d ₁	t ₁	t ₂	a	G	t ₁	t ₂	G	d ₁	d ₂	t ₁	t ₂	a		
mm	mm	mm	mm	mm	mm	mm	mm	mm	mm	mm	mm	mm	mm	mm	mm	mm	mm	mm	mm	mm	mm	mm	mm	
in	in	in	in	in	in	in	in	in	in	in	in	in	in	in	in	in	in	in	in	in	in	in	in	
				M14 x 1,5	20	12	18,5	1,5																
					0.79	0.47	0.73	0.06																
M10 x 1	11,5 +0.1	12	16,5	M16 x 1,5	22	12	18,5	1,5																
	0.45	0.47	0.65		0.87	0.47	0.73	0.06																
				G 1/4	19	12	18,5	1,5		G 1/4	19	12	18,5	1,5	R 1/4 taper	8,5	13,5							
					0.75	0.47	0.73	0.06			0.75	0.47	0.73	0.06		0.33	0.53							
				G 3/8	23	12	18,5	2,0							1/4 NPT	10	16,4		9/16 – 18 UNF	15,6	25	12,7	15,5	2,5
					0.91	0.47	0.73	0.08								0.39	0.65			0.61	0.98	0.50	0.61	0.10

3/00

TEST COUPLING SMK (compression ring fittings acc. to DIN 2353)

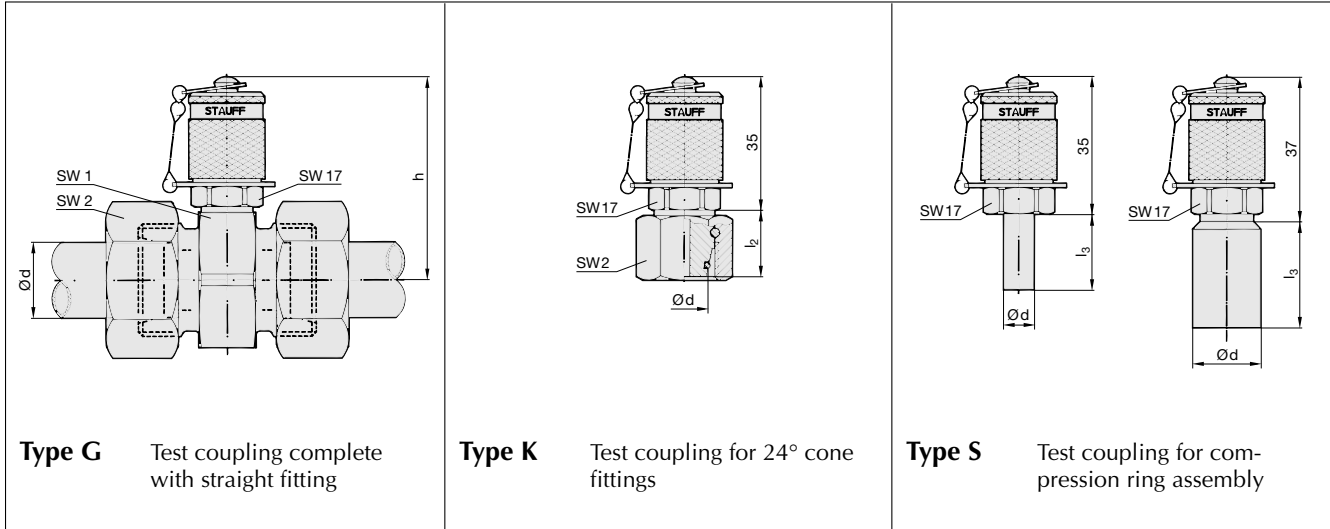

Type G Test coupling complete with straight fitting

Type K Test coupling for 24° cone fittings

Type S Test coupling for compression ring assembly

Series	PN* Psi (Bar)	Pipe Ød	l ₂		l ₃		h		SW 1		SW 2		Order No.*		
			mm	in	mm	in	mm	in	mm	in	mm	in	Type G	Type K	Type S
L	4500 (315)	6	15,5 0.61	20 0.79	49 1.93	24 0.94	14 0.55	SMK 15 – 6L-PG	SMK 15 – 6L-PK	SMK 15 – 6-PS					
		8	15,5 0.61	20 0.79	49 1.93	24 0.94	17 0.67	SMK 15 – 8L-PG	SMK 15 – 8L-PK	SMK 15 – 8-PS					
		10	16,5 0.65	22 0.87	49 1.93	24 0.94	19 0.75	SMK 15 – 10L-PG	SMK 15 – 10L-PK	SMK 15 – 10-PS					
		12	17,5 0.69	22 0.87	50,5 1.99	27 1.06	22 0.87	SMK 15 – 12L-PG	SMK 15 – 12L-PK	SMK 15 – 12-PS					
		15	21 0.83	25 0.98	52 2.05	30 1.18	27 1.06	SMK 15 – 15L-PG	SMK 15 – 15L-PK	SMK 15 – 15-PS					
		18	19,5 0.77	28 1.10	53 2.09	32 1.26	32 1.26	SMK 15 – 18L-PG	SMK 15 – 18L-PK	SMK 15 – 18-PS					
	2300 (160)	22	20,5 0.81	30 1.18	55 2.17	36 1.42	36 1.42	SMK 15 – 22L-PG	SMK 15 – 22L-PK	SMK 15 – 22-PS					
		28	25 0.98	32 1.26	57,5 2.26	41 1.61	41 1.61	SMK 15 – 28L-PG	SMK 15 – 28L-PK	SMK 15 – 28-PS					
		35	30 1.18	42 1.65	60 2.36	46 1.81	50 1.97	SMK 15 – 35L-PG	SMK 15 – 35L-PK	SMK 15 – 35-PS					
		42	31 1.22	45 1.77	64,5 2.54	55 2.17	60 2.36	SMK 15 – 42L-PG	SMK 15 – 42L-PK	SMK 15 – 42-PS					
S	9000 (630)	6	14,5 0.57	20 0.79	49 1.93	24 0.94	17 0.67	SMK 15 – 6S-PG	SMK 15 – 6S-PK	SMK 15 – 6-PS					
		8	16,5 0.65	20 0.79	49 1.93	24 0.94	19 0.75	SMK 15 – 8S-PG	SMK 15 – 8S-PK	SMK 15 – 8-PS					
		10	16,5 0.65	22 0.87	49 1.93	24 0.94	22 0.87	SMK 15 – 10S-PG	SMK 15 – 10S-PK	SMK 15 – 10-PS					
		12	17,5 0.69	22 0.87	49 1.93	24 0.94	24 0.94	SMK 15 – 12S-PG	SMK 15 – 12S-PK	SMK 15 – 12-PS					
		14	19,5 0.77	22 0.87	50,5 1.99	27 1.06	27 1.06	SMK 15 – 14S-PG	SMK 15 – 14S-PK	SMK 15 – 14-PS					
	5800 (400)	16	18 0.71	28 1.10	52 2.05	30 1.18	30 1.18	SMK 15 – 16S-PG	SMK 15 – 16S-PK	SMK 15 – 16-PS					
		20	24 0.94	30 1.18	55 2.17	36 1.42	36 1.42	SMK 15 – 20S-PG	SMK 15 – 20S-PK	SMK 15 – 20-PS					
		25	26 1.02	36 1.42	57,5 2.26	41 1.61	46 1.81	SMK 15 – 25S-PG	SMK 15 – 25S-PK	SMK 15 – 25-PS					
		30	30 1.18	41 1.61	60 2.36	46 1.81	50 1.97	SMK 15 – 30S-PG	SMK 15 – 30S-PK	SMK 15 – 30-PS					
	4500 315	38	34 1.34	48 1.89	64,5 2.54	55 2.17	60 2.36	SMK 15 – 38S-PG	SMK 15 – 38S-PK	SMK 15 – 38-PS					

* Working pressure
 * For ordering FPM seals please replace "P" with "V"
 * For EPDM seals replace "P" with "E"

3/00

TEST

TEST 15

TYPE SMK

CONNECTION THREAD M 16 X 1,5

TEST HOSE SMS (formerly HFF) (for gaseous media Specify Type SGS)

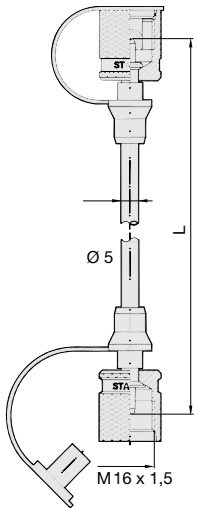
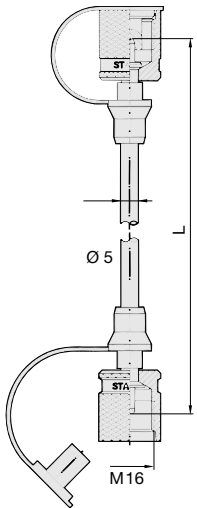
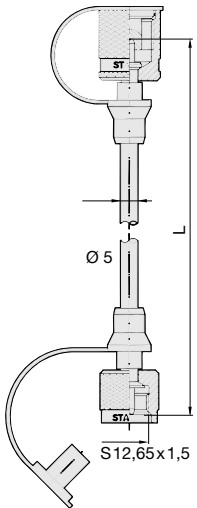
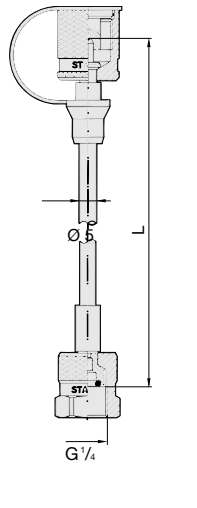
<p>Max. working pressure 9000 Psi (630 bar)</p> <p>Test hose: Nominal bore 0.08" (2 mm)</p> <p>Minimum bending radius 0.75" (20 mm)</p> <p>Pressure/t² factor:</p> <p>to 0°C 122 % at 30°C 110 % at 50°C 100 % at 80°C 86 % at 100°C 77 %</p> <p>Hose construction: Hose-core and -cover PA</p> <p>Reinforcement: Synthetic fibre</p> <p>Bursting pressure: 27,000 Psi (1900 bar)</p>	<p>Stauff-Test 15/15</p> <p>STAUFF-TEST 15</p>  <p>STAUFF-TEST 15</p>	<p>Stauff-Test 15/20</p> <p>STAUFF-TEST 15</p>  <p>STAUFF-TEST 20</p>	<p>Stauff-Test 12/15²⁾</p> <p>STAUFF-TEST 15</p>  <p>STAUFF-TEST 12</p>	<p>Stauff-Test 15/ 1/4" F</p> <p>STAUFF-TEST 15</p>  <p>GAUGE ADAPTOR</p>
	<p>Length L¹⁾</p>	<p>Order No.</p>		
12"	SMS-15-12-B	SMS-15/20-12-B	SMS-12/15-12-B	SMS-15/M 1/4-P-OR-12
24"	SMS-15-24-B	SMS-15/20-24-B	SMS-12/15-24-B	SMS-15/M 1/4-P-OR-24
36"	SMS-15-36-B	SMS-15/20-36-B	SMS-12/15-36-B	SMS-15/M 1/4-P-OR-36
48"	SMS-15-48-B	SMS-15/20-48-B	SMS-12/15-48-B	SMS-15/M 1/4-P-OR-48
60"	SMS-15-60-B	SMS-15/20-60-B	SMS-12/15-60-B	SMS-15/M 1/4-P-OR-60
72"	SMS-15-72-B	SMS-15/20-72-B	SMS-12/15-72-B	SMS-15/M 1/4-P-OR-72
96"	SMS-15-96-B	SMS-15/20-96-B	SMS-12/15-96-B	SMS-15/M 1/4-P-OR-96
120"	SMS-15-120-B	SMS-15/20-120-B	SMS-12/15-120-B	SMS-15/M 1/4-P-OR-120
Custom lengths available on request				
¹⁾ Bending protection and other lengths on request		²⁾ Special thread: buttress thread S12,65 x 1,5		³⁾ Gauge adaptor 1/4 NPT, G 1/2 and 1/2 NPT on request

GAUGE ADAPTOR SMA (formerly GAH)

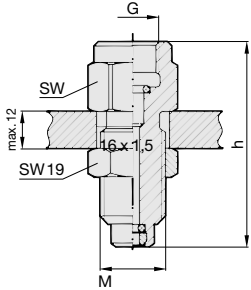
 <p>Through-hole Ø 18</p>	<p>G</p>	<p>h</p>	<p>SW</p>	Order No.		
				mm	in	NBR
<p>G 1/4</p>	<p>54</p>	<p>2.13</p>	<p>19</p>	<p>0.75</p>	SMA 15 - G 1/4 - P-OR	SMA 15 - G 1/4 - V-OR
					<p>64</p>	<p>2.52</p>
<p>1/4 NPT</p>	<p>54</p>	<p>2.13</p>	<p>19</p>	<p>0.75</p>	SMA 15 - 1/4 NPT-P	SMA 15 - 1/4 NPT-V
					<p>64</p>	<p>2.52</p>
Damping element on request						

BULKHEAD SSK (for gaseous media use Type SKK)

	<table border="1"> <thead> <tr> <th rowspan="2">G</th> <th colspan="2">h</th> <th rowspan="2">Type</th> <th colspan="2">Order No.</th> </tr> <tr> <th>mm</th> <th>in</th> <th>NBR</th> <th>FPM</th> </tr> </thead> <tbody> <tr> <td>M16 x 1,5</td> <td>72</td> <td>2.83</td> <td>A</td> <td>SSK 15-P</td> <td>SSK 15-V</td> </tr> <tr> <td>M16 x 1,5¹⁾</td> <td>72</td> <td>2.83</td> <td>B</td> <td>SSK 15/08 S-P</td> <td>SSK 15/08 S-V</td> </tr> </tbody> </table>	G	h		Type	Order No.		mm	in	NBR	FPM	M16 x 1,5	72	2.83	A	SSK 15-P	SSK 15-V	M16 x 1,5 ¹⁾	72	2.83	B	SSK 15/08 S-P	SSK 15/08 S-V
			G	h		Type	Order No.																
mm	in	NBR		FPM																			
M16 x 1,5	72	2.83	A	SSK 15-P	SSK 15-V																		
M16 x 1,5 ¹⁾	72	2.83	B	SSK 15/08 S-P	SSK 15/08 S-V																		
<p>¹⁾ Compression ring assembly 8 S acc. to DIN 2353</p>																							

DIRECT GAUGE ADAPTOR SMD (formerly DGA)

	<table border="1"> <thead> <tr> <th rowspan="2">G</th> <th colspan="2">h</th> <th rowspan="2">SW</th> <th colspan="2">Order No.</th> </tr> <tr> <th>mm</th> <th>in</th> <th>mm</th> <th>in</th> <th>NBR</th> <th>FPM</th> </tr> </thead> <tbody> <tr> <td>G 1/4</td> <td>41</td> <td>1.61</td> <td>19</td> <td>0.75</td> <td>SMD 15 - G 1/4 - P-OR</td> <td>SMD 15 - G 1/4 - V-OR</td> </tr> <tr> <td>G 1/2</td> <td>51</td> <td>2.01</td> <td>27</td> <td>1.06</td> <td>SMD 15 - G 1/2 - P-OR</td> <td>SMD 15 - G 1/2 - V-OR</td> </tr> <tr> <td>1/4 NPT</td> <td>41</td> <td>1.61</td> <td>19</td> <td>0.75</td> <td>SMD 15 - 1/4 NPT-P</td> <td>SMD 15 - 1/4 NPT-V</td> </tr> <tr> <td>1/2 NPT</td> <td>51</td> <td>2.01</td> <td>27</td> <td>1.06</td> <td>SMD 15 - 1/2 NPT-P</td> <td>SMD 15 - 1/2 NPT-V</td> </tr> </tbody> </table>	G	h		SW	Order No.		mm	in	mm	in	NBR	FPM	G 1/4	41	1.61	19	0.75	SMD 15 - G 1/4 - P-OR	SMD 15 - G 1/4 - V-OR	G 1/2	51	2.01	27	1.06	SMD 15 - G 1/2 - P-OR	SMD 15 - G 1/2 - V-OR	1/4 NPT	41	1.61	19	0.75	SMD 15 - 1/4 NPT-P	SMD 15 - 1/4 NPT-V	1/2 NPT	51	2.01	27	1.06	SMD 15 - 1/2 NPT-P	SMD 15 - 1/2 NPT-V
			G	h		SW	Order No.																																		
mm	in	mm		in	NBR		FPM																																		
G 1/4	41	1.61	19	0.75	SMD 15 - G 1/4 - P-OR	SMD 15 - G 1/4 - V-OR																																			
G 1/2	51	2.01	27	1.06	SMD 15 - G 1/2 - P-OR	SMD 15 - G 1/2 - V-OR																																			
1/4 NPT	41	1.61	19	0.75	SMD 15 - 1/4 NPT-P	SMD 15 - 1/4 NPT-V																																			
1/2 NPT	51	2.01	27	1.06	SMD 15 - 1/2 NPT-P	SMD 15 - 1/2 NPT-V																																			
<p>Damping element on request</p>																																									

WELDING ADAPTOR SAS

	<table border="1"> <thead> <tr> <th rowspan="2">Thread G</th> <th colspan="2">h</th> <th rowspan="2">Ød</th> <th rowspan="2">Order No.</th> </tr> <tr> <th>mm</th> <th>in</th> <th>mm</th> <th>in</th> </tr> </thead> <tbody> <tr> <td>M10 x 1</td> <td>25</td> <td>0.98</td> <td>20</td> <td>0.79</td> <td>SAS - M10 x 1</td> </tr> <tr> <td>G 1/4</td> <td>30</td> <td>1.18</td> <td>22</td> <td>0.87</td> <td>SAS - G 1/4</td> </tr> </tbody> </table>	Thread G	h		Ød	Order No.	mm	in	mm	in	M10 x 1	25	0.98	20	0.79	SAS - M10 x 1	G 1/4	30	1.18	22	0.87	SAS - G 1/4
			Thread G	h			Ød	Order No.														
mm	in	mm		in																		
M10 x 1	25	0.98	20	0.79	SAS - M10 x 1																	
G 1/4	30	1.18	22	0.87	SAS - G 1/4																	
<p>Material: St 37</p>																						

3/00

TEST

TEST 12

TYPE SKK

CONNECTION THREAD S 12,65 X 1,5

TEST

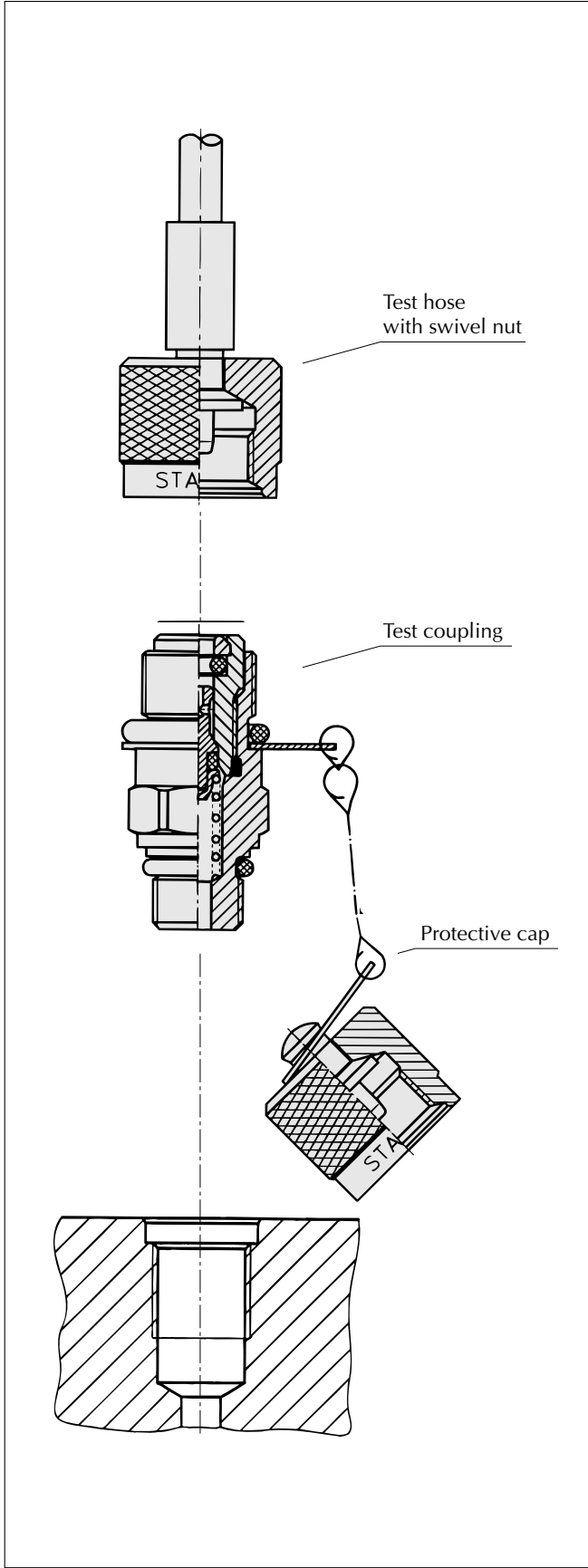

FAST COUPLING FOR:

- Monitoring and control of pressure
- Venting
- Sampling

ADVANTAGES:

- Coupling at system pressure level
- Connection is leakproof before **piston valve** is open
- Simple connection to measurement, control and switching devices
- Self locking metal protective cap

WORKING PRESSURE:

- Max. working pressure 9000 Psi (630 bar)
For SKK type G, K and S the recommended working pressure of fitting manufacturer should be noted
- Connection under pressure up to 5800 Psi (400 bar) max.

MATERIALS:

- Metal parts: Steel, Stainless Steel on request
- Seals:
 - P = NBR-BUNA Temperature range - 4°F to +195°F (- 20° C to +90° C)
 - V = FPM-VITON Temperature range - 4°F to +392°F (- 20° C to +200° C)
 - E = EPDM Ethylene Propylene (for Brake Fluid) Temperature range - 40°F to +302°F (- 40° C to + 150° C)
- Hose: Polyamide Temperature range -31°F to +212°F (-35° C to +100° C)

MEDIA:

- Suitable for hydraulic oils and other mineral oil based fluids (check compatibility of seal material)
- For use with other liquid media please consult STAUFF for availability of alternate seals

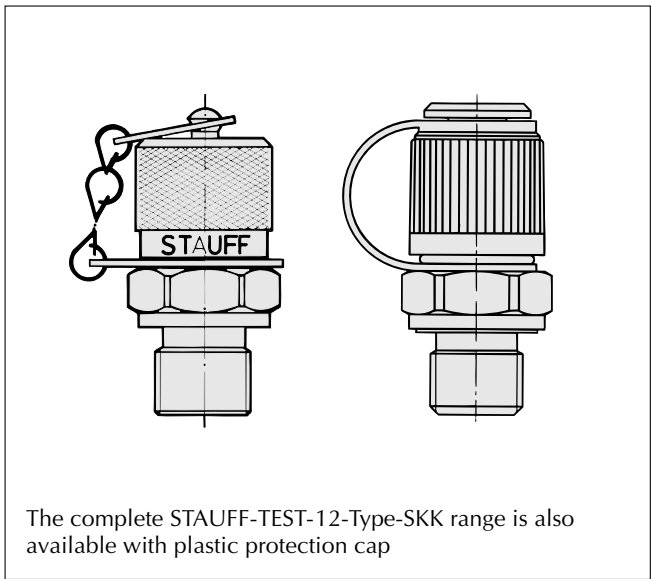

The complete STAUFF-TEST-12-Type-SKK range is also available with plastic protection cap

3/00

TEST COUPLING WITH PROTECTIVE CAP SKK (formerly SMK)

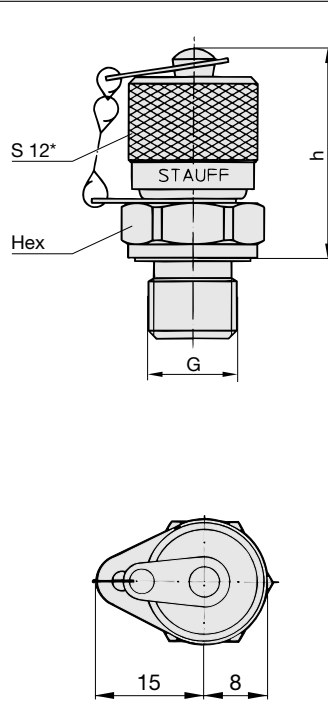

Thread G	h		Hex		Order No.		Seal
	mm	in	mm	in	NBR (BUNA)	FPM (VITON)	
M8 x 1	37	1.46	14	0.55	SKK 12 – M8 x 1 – PA	SKK 12 – M8 x 1 – VA	O-Ring Type A
M10 x 1	34	1.34	14	0.55	SKK 12 – M10 x 1 – PA	SKK 12 – M10 x 1 – VA	O-Ring Type A
M12 x 1,5	31	1.22	17	0.67	SKK 12 – M12 x 1,5 – PC	SKK 12 – M12 x 1,5 – VC	O-Ring Type C
M14 x 1,5	31	1.22	19	0.75	SKK 12 – M14 x 1,5 – PB	SKK 12 – M14 x 1,5 – VB	Metal joint Type B
M16 x 1,5	31	1.22	22	0.87	SKK 12 – M16 x 1,5 – PB	SKK 12 – M16 x 1,5 – VB	Metal joint Type B
G 1/8	40	1.57	14	0.55	SKK 12 – G 1/8 – PC	SKK 12 – G 1/8 – VC	O-Ring Type C
G 1/4	31	1.22	19	0.75	SKK 12 – G 1/4 – PB	SKK 12 – G 1/4 – VB	Metal joint Type B
G 1/4	31	1.22	19	0.75	SKK 12 – G 1/4 – PC	SKK 12 – G 1/4 – VC	O-Ring Type C
G 3/8	31	1.22	22	0.87	SKK 12 – G 3/8 – PB	SKK 12 – G 3/8 – VB	Metal joint Type B
R 1/8 taper	33	1.30	14	0.55	SKK 12 – R 1/8 K-PD	SKK 12 – R 1/8 K-VD	Taper Type D
R 1/4 taper	30	1.18	14	0.55	SKK 12 – R 1/4 K-PD	SKK 12 – R 1/4 K-VD	Taper Type D
1/8 NPT	33	1.30	14	0.55	SKK 12 – 1/8 NPT-PD	SKK 12 – 1/8 NPT-VD	Taper Type D
1/4 NPT	28	1.10	14	0.55	SKK 12 – 1/4 NPT-PD	SKK 12 – 1/4 NPT-VD	Taper Type D
5/16 – 24 UNF	34,5	1.36	17	0.67	SKK 12 – 5/16 UNF-PE	SKK 12 – 5/16 UNF-VE	O-Ring Type E
7/16 – 20 UNF	33	1.30	17	0.67	SKK 12 – 7/16 UNF-PE	SKK 12 – 7/16 UNF-VE	O-Ring Type E
1/2 – 20 UNF	32	1.26	17	0.67	SKK 12 – 1/2 UNF-PE	SKK 12 – 1/2 UNF-VE	O-Ring Type E
9/16 – 18 UNF	32	1.26	19	0.75	SKK 12 – 9/16 UNF-PE	SKK 12 – 9/16 UNF-VE	O-Ring Type E

*** Special thread:**
buttress thread S 12,65 x 1,5

Other port connections and seals on request.

PORT CONNECTIONS AND SEALS

Type A				Type B					Type C					Type D			Type E						
G	d ₁	t ₁	t ₂	G	d ₁	t ₁	t ₂	a	G	d ₁	t ₁	t ₂	a	G	t ₁	t ₂	G	d ₁	d ₂	t ₁	t ₂	a	
	mm	mm	mm	mm	mm	mm	mm	mm	mm	mm	mm	mm	mm	mm	mm	mm	mm	mm	mm	mm	mm	mm	mm
	in	in	in	in	in	in	in	in	in	in	in	in	in	in	in	in	in	in	in	in	in	in	in
M8 x 1	9,5 + 0,1	11	15,5	M14 x 1,5	20	12	18,5	1,5	M12 x 1,5	18	12	18,5	1,5	R 1/8 taper	5,5	9,5	5/16 – 24 UNF	9,1	17	10	12	1,9	
	0.37	0.43	0.61		0.79	0.47	0.73	0.06		0.71	0.47	0.73	0.06		0.22	0.37		0.36	0.67	0.39	0.47	0.07	
M10 x 1	11,5 + 0,1	12	16,5	M16 x 1,5	22	12	18,5	1,5	G 1/8	15	8	13	1,0	R 1/4 taper	8,5	13,5	7/16 – 20 UNF	12,4	21	11,5	14	2,4	
	0.45	0.47	0.65		0.87	0.47	0.73	0.06		0.59	0.31	0.51	0.04		0.33	0.53		0.49	0.83	0.45	0.55	0.09	
				G 1/4	19	12	18,5	1,5	G 1/4	19	12	18,5	1,5	1/8 NPT	6,9	11,6	1/2 – 20 UNF	14	23	11,5	14	2,4	
					0.75	0.47	0.73	0.06		0.75	0.47	0.73	0.06		0.27	0.46		0.55	0.91	0.45	0.55	0.09	
				G 3/8	23	12	18,5	2	1/4 NPT	10				1/4 NPT	10	16,4	9/16 – 18 UNF	15,6	25	12,7	15,5	2,5	
					0.91	0.47	0.73	0.08							0.39	0.65		0.61	0.98	0.50	0.61	0.10	

3/00

TEST 12

TYPE SKK

CONNECTION THREAD S 12,65 X 1,5

TEST COUPLING SKK (compression ring fittings acc. to DIN 2353)

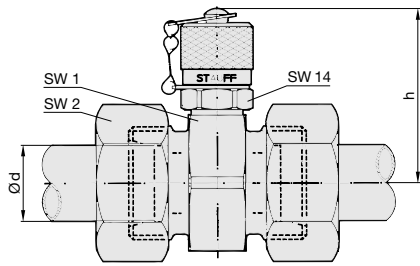

Type G Test coupling complete with straight fitting

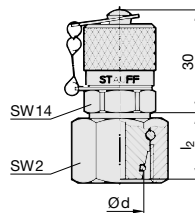

Type K Test coupling for 24° cone fittings

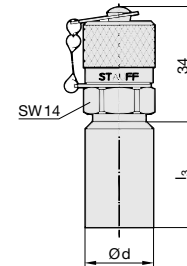

Type S Test coupling for compression ring assembly

Series	PN	Pipe Ød	l ₂		l ₃		h		SW 1		SW 2		Order No.*		
			mm	in	mm	in	mm	in	mm	in	mm	in	Type G	Type K	Type S
L	315	6	15,5	0.61	20	0.79	46	1.81	24	0.94	14	0.55	SKK 12 – 6L-PG	SKK 12 – 6L-PK	SKK 12 – 6-PS
		8	15,5	0.61	20	0.79	46	1.81	24	0.94	17	0.67	SKK 12 – 8L-PG	SKK 12 – 8L-PK	SKK 12 – 8-PS
		10	16,5	0.65	22	0.87	46	1.81	24	0.94	19	0.75	SKK 12 – 10L-PG	SKK 12 – 10L-PK	SKK 12 – 10-PS
		12	17,5	0.69	22	0.87	47,5	1.87	27	1.06	22	0.87	SKK 12 – 12L-PG	SKK 12 – 12L-PK	SKK 12 – 12-PS
		15	21	0.83	25	0.98	49	1.93	30	1.18	27	1.06	SKK 12 – 15L-PG	SKK 12 – 15L-PK	SKK 12 – 15-PS
		18	19,5	0.77	28	1.10	50	1.97	32	1.26	32	1.26	SKK 12 – 18L-PG	SKK 12 – 18L-PK	SKK 12 – 18-PS
	160	22	20,5	0.81	30	1.18	52	2.05	36	1.42	36	1.42	SKK 12 – 22L-PG	SKK 12 – 22L-PK	SKK 12 – 22-PS
		28	25	0.98	32	1.26	54,5	2.15	41	1.61	41	1.61	SKK 12 – 28L-PG	SKK 12 – 28L-PK	SKK 12 – 28-PS
		35	30	1.18	42	1.65	57	2.24	46	1.81	50	1.97	SKK 12 – 35L-PG	SKK 12 – 35L-PK	SKK 12 – 35-PS
		42	31	1.22	45	1.77	61,5	2.42	55	2.17	60	2.36	SKK 12 – 42L-PG	SKK 12 – 42L-PK	SKK 12 – 42-PS
S	630	6	14,5	0.57	20	0.79	46	1.81	24	0.94	17	0.67	SKK 12 – 6S-PG	SKK 12 – 6S-PK	SKK 12 – 6-PS
		8	16,5	0.65	20	0.79	46	1.81	24	0.94	19	0.75	SKK 12 – 8S-PG	SKK 12 – 8S-PK	SKK 12 – 8-PS
		10	16,5	0.65	22	0.87	46	1.81	24	0.94	22	0.87	SKK 12 – 10S-PG	SKK 12 – 10S-PK	SKK 12 – 10-PS
		12	17,5	0.69	22	0.87	46	1.81	24	0.94	24	0.94	SKK 12 – 12S-PG	SKK 12 – 12S-PK	SKK 12 – 12-PS
		14	19,5	0.77	22	0.87	47,5	1.87	27	1.06	27	1.06	SKK 12 – 14S-PG	SKK 12 – 14S-PK	SKK 12 – 14-PS
	400	16	18	0.71	28	1.10	49	1.93	30	1.18	30	1.18	SKK 12 – 16S-PG	SKK 12 – 16S-PK	SKK 12 – 16-PS
		20	24	0.94	30	1.18	52	2.05	36	1.42	36	1.42	SKK 12 – 20S-PG	SKK 12 – 20S-PK	SKK 12 – 20-PS
		25	26	1.02	36	1.42	54,5	2.15	41	1.61	46	1.81	SKK 12 – 25S-PG	SKK 12 – 25S-PK	SKK 12 – 25-PS
		30	30	1.18	41	1.61	57	2.24	46	1.81	50	1.97	SKK 12 – 30S-PG	SKK 12 – 30S-PK	SKK 12 – 30-PS
		315	38	1.34	48	1.89	61,5	2.42	55	2.17	60	2.36	SKK 12 – 38S-PG	SKK 12 – 38S-PK	SKK 12 – 38-PS

* For ordering FPM seals please replace "P" with "V"
 * For EPDM seals replace "P" with "E"

TEST HOSE SMS (for gaseous media Specify Type **SGS**) (formerly HFF)

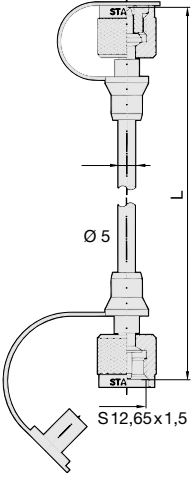
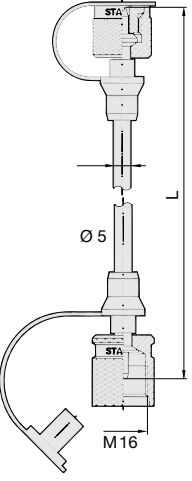
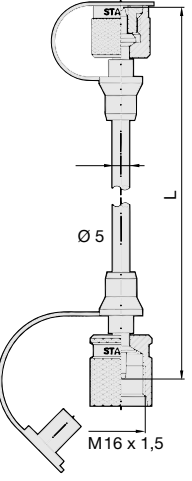
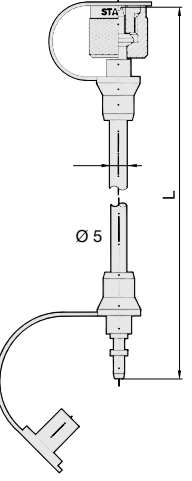
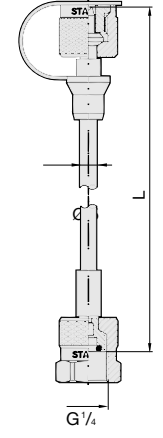
Max. working pressure 5800 Psi (400 bar) Test hose: Nominal bore 0.08" (2 mm) Minimum bending radius 0.75" (20 mm) Nominal bore 0.16" (4 mm) also available Pressure/t ² factor: to 0°C 122 % at 30°C 110 % at 50°C 100 % at 80°C 86 % at 100°C 77 % Hose construction: Hose-core and -cover PA 11/12 Reinforcement: Synthetic fibre Bursting pressure: 15,950 Psi (1100 bar)	Stauff-Test 12/12 ²⁾ STAUFF-TEST 12 	Stauff-Test 12/20 STAUFF-TEST 12 	Stauff-Test 12/15 STAUFF-TEST 12 	Stauff-Test 10/12 STAUFF-TEST 12 	Stauff-Test 12/M ¹ / ₄ -P-OR ³⁾ STAUFF-TEST 12 
	STAUFF-TEST 12 Ø 5 S12,65x1,5	STAUFF-TEST 20 Ø 5 M16	STAUFF-TEST 15 Ø 5 M16 x 1,5	STAUFF-TEST 10 Ø 5	GAUGE ADAPTOR G ¹ / ₄
Length L ¹⁾	Order No.				
12"	SMS-12-12-A	SMS-12/20-12-A	SMS-12/15-12-A	SMS-10/12-12-A	SMS-12/M ¹ / ₄ -P-OR-12
24"	SMS-12-24-A	SMS-12/20-24-A	SMS-12/15-24-A	SMS-10/12-24-A	SMS-12/M ¹ / ₄ -P-OR-24
36"	SMS-12-36-A	SMS-12/20-36-A	SMS-12/15-36-A	SMS-10/12-36-A	SMS-12/M ¹ / ₄ -P-OR-36
48"	SMS-12-48-A	SMS-12/20-48-A	SMS-12/15-48-A	SMS-10/12-48-A	SMS-12/M ¹ / ₄ -P-OR-48
60"	SMS-12-60-A	SMS-12/20-60-A	SMS-12/15-60-A	SMS-10/12-60-A	SMS-12/M ¹ / ₄ -P-OR-60
72"	SMS-12-72-A	SMS-12/20-72-A	SMS-12/15-72-A	SMS-10/12-72-A	SMS-12/M ¹ / ₄ -P-OR-72
96"	SMS-12-96-A	SMS-12/20-96-A	SMS-12/15-96-A	SMS-10/12-96-A	SMS-12/M ¹ / ₄ -P-OR-96
120"	SMS-12-120-A	SMS-12/20-120-A	SMS-12/15-120-A	SMS-10/12-120-A	SMS-12/M ¹ / ₄ -P-OR-120
Custom lengths available on request					
¹⁾ Bending protection and other lengths on request		²⁾ Special thread: buttress thread S12,65 x 1,5		³⁾ Gauge adaptor 1/4 NPT, G 1/2 and 1/2 NPT on request	

ADAPTOR SAD

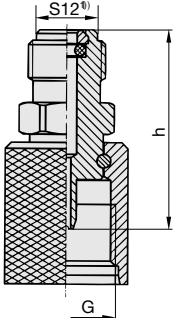
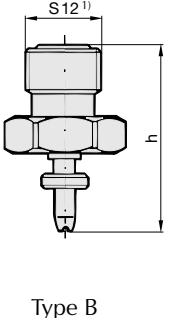
 <p>Type A</p>	 <p>Type B</p>	G	h	Type	Order No.	
			mm / in			NBR (BUNA)
		M16 x 1,5	33 / 1.30	A	SAD 12/15-P	SAD 12/15-V
		plug in	31 / 1.22	B	SAD 12/10-P	SAD 12/10-V
		M16 x 2	33 / 1.30	A	SAD 12/20-P	SAD 12/20-V
¹⁾ Special thread: buttress thread S12,65 x 1,5						

3/00

BULKHEAD SSKK (formerly SSK)

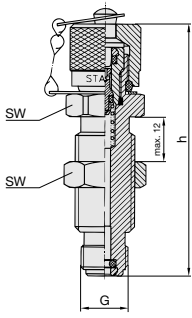
	G	h		SW		Order No.	
		mm	in	mm	in	NBR	FPM
	S12	63	2.48	19	0.75	SSKK 12-P	SSKK 12-V

GAUGE ADAPTOR SMA (formerly GAH 12)

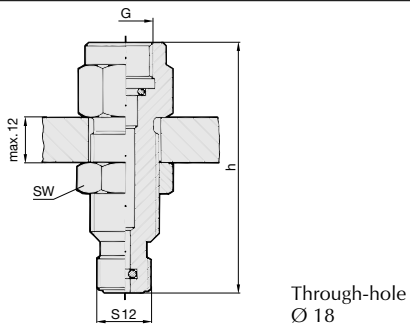
	G	h		SW		Order No.	
		mm	in	mm	in	NBR	FPM
	G 1/4	51	2.00	19	0.75	SMA 12 - G 1/4 - P-OR	SMA 12 - G 1/4 - V-OR
	G 1/2	61	2.40	27	1.06	SMA 12 - G 1/2 - P-OR	SMA 12 - G 1/2 - V-OR
	1/4 NPT	51	2.00	19	0.75	SMA 12 - 1/4 NPT-P	SMA 12 - 1/4 NPT-V
	1/2 NPT	61	2.40	27	1.06	SMA 12 - 1/2 NPT-P	SMA 12 - 1/2 NPT-V
Damping element on request							

DIRECT GAUGE ADAPTOR SMD (formerly DGA 12)

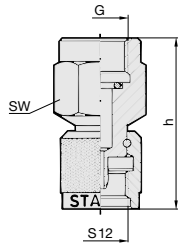
	G	h		SW		Order No.	
		mm	in	mm	in	NBR	FPM
	G 1/4	35	1.38	19	0.75	SMD 12 - G 1/4 - P-OR	SMD 12 - G 1/4 - V-OR
	G 1/2	45	1.77	27	1.06	SMD 12 - G 1/2 - P-OR	SMD 12 - G 1/2 - V-OR
	1/4 NPT	35	1.38	19	0.75	SMD 12 - 1/4 NPT-P	SMD 12 - 1/4 NPT-V
	1/2 NPT	45	1.77	27	1.06	SMD 12 - 1/2 NPT-P	SMD 12 - 1/2 NPT-V
Damping element on request							

WELDING ADAPTOR SAS

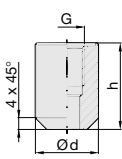
	Coupling thread G	h		Ød		Order No.
		mm	in	mm	in	
	M10 x 1	25	0.98	20	0.79	SAS - M10 x 1
	G 1/4	30	1.18	22	0.87	SAS - G 1/4

THREAD ADAPTOR SRS

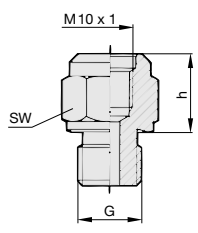
	Thread G	h		SW		Order No.	Seal
		mm	in	mm	in		
	M16 x 1,5	8	0.31	22	0.87	SRS 20 - M16 x 1,5-B	Metal joint DIN 3852 Type B
	G 1/8	15,5	0.61	17	0.67	SRS 20 - G 1/8-B	
	G 3/8	10,5	0.41	22	0.87	SRS 20 - G 3/8-B	
	G 1/2	10,5	0.41	27	1.06	SRS 20 - G 1/2-B	
	R 1/4 taper	13	0.51	19	0.75	SRS 20 - R 1/4 K-D	Port Connection Type D

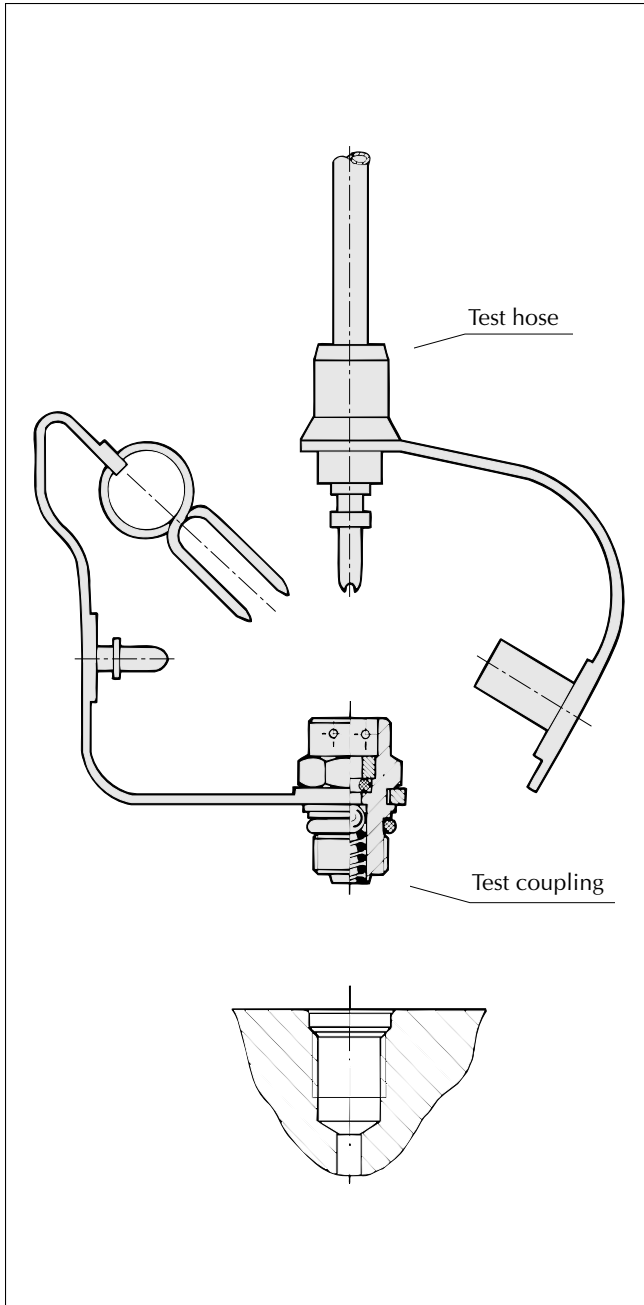

FAST COUPLING FOR:

- Monitoring and control of pressure
- Venting
- Sampling

ADVANTAGES:

- Coupling at system pressure level
- Connection is leakproof before **ball valve** is open
- Simple connection to measurement, control and switching devices

WORKING PRESSURE:

- Max. working pressure 5800 Psi (400 bar)
For SMK Type G, K and S the recommended working pressure of fitting manufacturer should be noted

MATERIALS:

- Metal parts: Steel, Stainless Steel on request
- Ball: Stainless Steel
- Seals:
 - P = NBR-BUNA Temperature range - 4°F to +195°F (- 20° C to +90° C)
 - V = FPM-VITON Temperature range - 4°F to +392°F (- 20° C to +200° C)
 - E = EPDM Ethylene Propylene (for Brake Fluid) Temperature range - 40°F to +302°F (- 40° C to + 150° C)
- Hose: Polyamide Temperature range -31°F to +212°F (-35° C to +100° C)

MEDIA:

- Suitable for hydraulic oils and other mineral oil based fluids (check compatibility of seal material)
- For use with other liquid media please consult STAUFF for availability of alternate seals

Port connections

Type A					Type D				
	d_1 (G)	d_2	t_1	t_2		d_1 (G)	t_1	t_2	
		mm in	mm in	mm in			mm in	mm in	
	M 8 x 1	9,5 + 0,1	11	15,5		R 1/8 taper	5,5	9,5	
		0.37	0.43	0.61			0.22	0.37	
M 10 x 1	11,5 + 0,1	12	16,5						
	0.45	0.47	0.65						

3/00

TEST 10

TYPE SMK

PLUG IN SYSTEM

TEST COUPLING WITH PROTECTIVE CAP SMK

	Thread G	H	Order No.		Seal
			NBR (BUNA)	FPM (VITON)	
	M8 x 1	17,5 0.69	SMK 10 – M8 x 1 – PA	SMK 10 – M8 x 1 – VA	O-Ring Type A
	M10 x 1	17,5 0.69	SMK 10 – M10 x 1 – PA	SMK 10 – M10 x 1 – VA	O-Ring Type A
R 1/80 taper	17,5 0.69	SMK 10 – R 1/80 K-PD	SMK 10 – R 1/80 K-VD	Taper Type D	

TEST COUPLING SMK (compression ring fittings acc. to DIN 2353)

<p>Type G Test coupling complete with straight fitting</p>	<p>Type K Test coupling for 24° cone fittings</p>	<p>Type S Test coupling for compression ring assembly (not to be used for new constructions)</p>
---	--	---

Series	PN	Pipe Ød	l ₂			l ₃			l ₄			h			SW 1			SW 2			SW 3			Order No.*		
			mm	in	mm	in	mm	in	mm	in	mm	in	mm	in	mm	in	mm	in	mm	in	mm	in	mm	in	Type G	Type K
L	315	6	30,5	1.20	20	0.79	36	1.42	29,5	1.16	24	0.94	14	0.55	SMK 10 – 6L-PG	SMK 10 – 6L-PK	SMK 10 – 6-PS									
		8	30,5	1.20	20	0.79	36	1.42	29,5	1.16	24	0.94	17	0.67	SMK 10 – 8L-PG	SMK 10 – 8L-PK	SMK 10 – 8-PS									
		10	31,5	1.24	22	0.87	38	1.50	29,5	1.16	24	0.94	19	0.75	SMK 10 – 10L-PG	SMK 10 – 10L-PK	SMK 10 – 10-PS									
		12	32,5	1.28	22	0.87	38	1.50	31	1.22	27	1.06	22	0.87	SMK 10 – 12L-PG	SMK 10 – 12L-PK	SMK 10 – 12-PS									
		15	21	0.83			28	1.10	32,5	1.28	30	1.18	27	1.06	SMK 10 – 15L-PG	SMK 10 – 15L-PK	SMK 10 – 15-PS									
		18	19,5	0.77			28	1.10	33,5	1.32	32	1.26	32	1.26	SMK 10 – 18L-PG	SMK 10 – 18L-PK	SMK 10 – 18-PS									
	160	22	20,5	0.81			30	1.18	35,5	1.40	36	1.42	36	1.42	SMK 10 – 22L-PG	SMK 10 – 22L-PK	SMK 10 – 22-PS									
		28	25	0.98			32	1.26	38	1.50	41	1.61	41	1.61	SMK 10 – 28L-PG	SMK 10 – 28L-PK	SMK 10 – 28-PS									
		35	30	1.18			42	1.65	40,5	1.59	46	1.81	50	1.97	SMK 10 – 35L-PG	SMK 10 – 35L-PK	SMK 10 – 35-PS									
		42	31	1.22			45	1.77	45	1.77	55	2.17	60	2.36	SMK 10 – 42L-PG	SMK 10 – 42L-PK	SMK 10 – 42-PS									
S	630	6	29,5	1.16	20	0.79	36	1.42	29,5	1.16	24	0.94	17	0.67	SMK 10 – 6S-PG	SMK 10 – 6S-PK	SMK 10 – 6-PS									
		8	31,5	1.24	20	0.79	36	1.42	29,5	1.16	24	0.94	19	0.75	SMK 10 – 8S-PG	SMK 10 – 8S-PK	SMK 10 – 8-PS									
		10	31,5	1.24	22	0.87	38	1.50	29,5	1.16	24	0.94	22	0.87	SMK 10 – 10S-PG	SMK 10 – 10S-PK	SMK 10 – 10-PS									
		12	32,5	1.28	22	0.87	38	1.50	29,5	1.16	24	0.94	24	0.94	SMK 10 – 12S-PG	SMK 10 – 12S-PK	SMK 10 – 12-PS									
		14	19,5	0.77	22	0.87	38	1.50	31	1.22	27	1.06	27	1.06	SMK 10 – 14S-PG	SMK 10 – 14S-PK	SMK 10 – 14-PS									
	400	16	28	1.10			28	1.10	32,5	1.28	30	1.18	30	1.18	SMK 10 – 16S-PG	SMK 10 – 16S-PK	SMK 10 – 16-PS									
		20	24	0.94			30	1.18	35,5	1.40	36	1.42	36	1.42	SMK 10 – 20S-PG	SMK 10 – 20S-PK	SMK 10 – 20-PS									
		25	26	1.02			36	1.42	38	1.50	41	1.61	46	1.81	SMK 10 – 25S-PG	SMK 10 – 25S-PK	SMK 10 – 25-PS									
		30	30	1.18			41	1.61	40,5	1.59	46	1.81	50	1.97	SMK 10 – 30S-PG	SMK 10 – 30S-PK	SMK 10 – 30-PS									
		315	38	34	1.34			48	1.89	45	1.77	55	2.17	60	2.36	SMK 10 – 38S-PG	SMK 10 – 38S-PK	SMK 10 – 38-PS								

* For ordering FPM seals please replace "P" with "V"
 * For EPDM seals replace "P" with "E"

TEST HOSE SMS (formerly HFF)

	Length L	Order No.	Notice										
	12"	SMS-10-12-A	<p>Nominal bore 0.08" (2 mm)</p> <p>Minimum bending radius 0.75" (20 mm)</p> <p>Pressure/t° factor</p> <table border="1"> <tr> <td>to 0° C</td> <td>122%</td> </tr> <tr> <td>at 30° C</td> <td>110%</td> </tr> <tr> <td>at 50° C</td> <td>100%</td> </tr> <tr> <td>at 80° C</td> <td>86%</td> </tr> <tr> <td>at 100° C</td> <td>77%</td> </tr> </table> <p>Bending protection and other lengths on request.</p>	to 0° C	122%	at 30° C	110%	at 50° C	100%	at 80° C	86%	at 100° C	77%
	to 0° C	122%											
	at 30° C	110%											
	at 50° C	100%											
	at 80° C	86%											
	at 100° C	77%											
	24"	SMS-10-24-A											
	36"	SMS-10-36-A											
48"	SMS-10-48-A												
60"	SMS-10-60-A												
72"	SMS-10-72-A												
96"	SMS-10-96-A												
120"	SMS-10-120-A												

TEST HOSE SMS for direct gauge adaptor

	Length L	Order No.	Notice										
	12"	SMS-10/M ¹ / ₄ -P-OR-12	<p>Nominal bore 0.08" (2 mm)</p> <p>Minimum bending radius 0.75" 20 mm</p> <p>Pressure/t° factor</p> <table border="1"> <tr> <td>to 0° C</td> <td>122%</td> </tr> <tr> <td>at 30° C</td> <td>110%</td> </tr> <tr> <td>at 50° C</td> <td>100%</td> </tr> <tr> <td>at 80° C</td> <td>86%</td> </tr> <tr> <td>at 100° C</td> <td>77%</td> </tr> </table> <p>Bending protection and other lengths on request.</p>	to 0° C	122%	at 30° C	110%	at 50° C	100%	at 80° C	86%	at 100° C	77%
	to 0° C	122%											
	at 30° C	110%											
	at 50° C	100%											
	at 80° C	86%											
	at 100° C	77%											
	24"	SMS-10/M ¹ / ₄ -P-OR-24											
	36"	SMS-10/M ¹ / ₄ -P-OR-36											
48"	SMS-10/M ¹ / ₄ -P-OR-48												
60"	SMS-10/M ¹ / ₄ -P-OR-60												
72"	SMS-10/M ¹ / ₄ -P-OR-72												
96"	SMS-10/M ¹ / ₄ -P-OR-96												
120"	SMS-10/M ¹ / ₄ -P-OR-120												

GAUGE ADAPTOR SMA (formerly GAH 10)

	G	H		SW		Order No.	
		mm	in	mm	in	NBR	FPM
	G ¹ / ₄	57	2.24	19	0.75	SMA 10 – G ¹ / ₄ – P-OR	SMA 10 – G ¹ / ₄ – V-OR
	G ¹ / ₂	67	2.64	27	1.06	SMA 10 – G ¹ / ₂ – P-OR	SMA 10 – G ¹ / ₂ – V-OR
	¹ / ₄ NPT	57	2.24	19	0.75	SMA 10 – ¹ / ₄ NPT – P	SMA 10 – ¹ / ₄ NPT – V
	¹ / ₂ NPT	67	2.64	27	1.06	SMA 10 – ¹ / ₂ NPT – P	SMA 10 – ¹ / ₄ NPT – V
Damping element on request							

Through-hole Ø 18

3/00

TEST

PRESSURE GAUGES

TYPE SPG, WPG

SPECIFICATIONS

- Copper Alloy Bourden Tube
- Dual Scales
- Built in Relief Valve
- Operating Temperatures
Ambient -4°F to 140°F (-20°C to 60°C)
Media 140°F (+60°C)
- Acrylic Lens
- Accuracy + 1.5% of Full Scale
- Built in Snubber

OPTIONS

- 2 1/2" or 4" Diameter Available
- Forged Brass Case Available in 2 1/2" Version.
- Stainless Steel Case Available in 2 1/2" and 4" Version.
- Front Flange
- Custom Dials & Pressure Gauges Available on Special Request.



DIMENSIONS

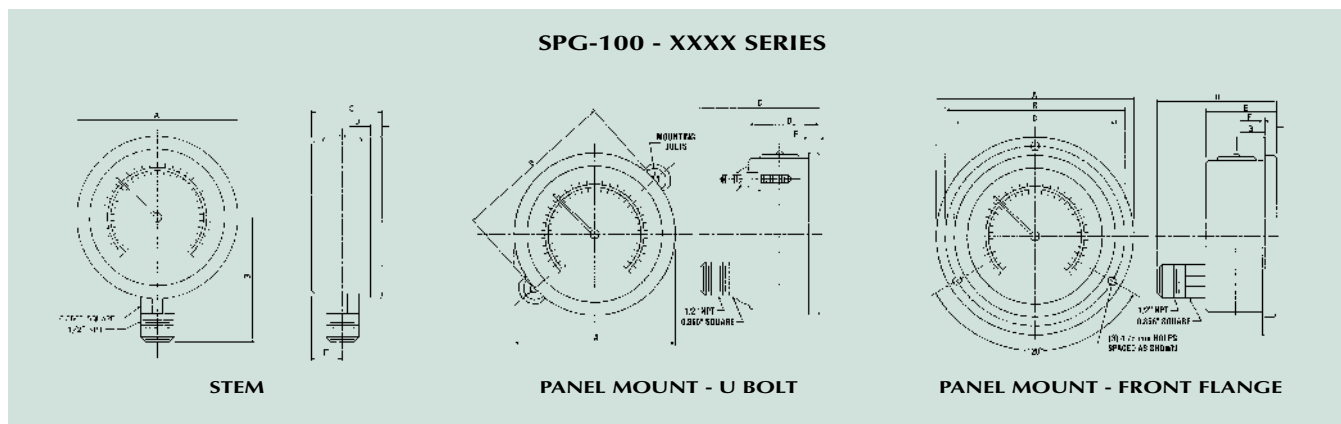
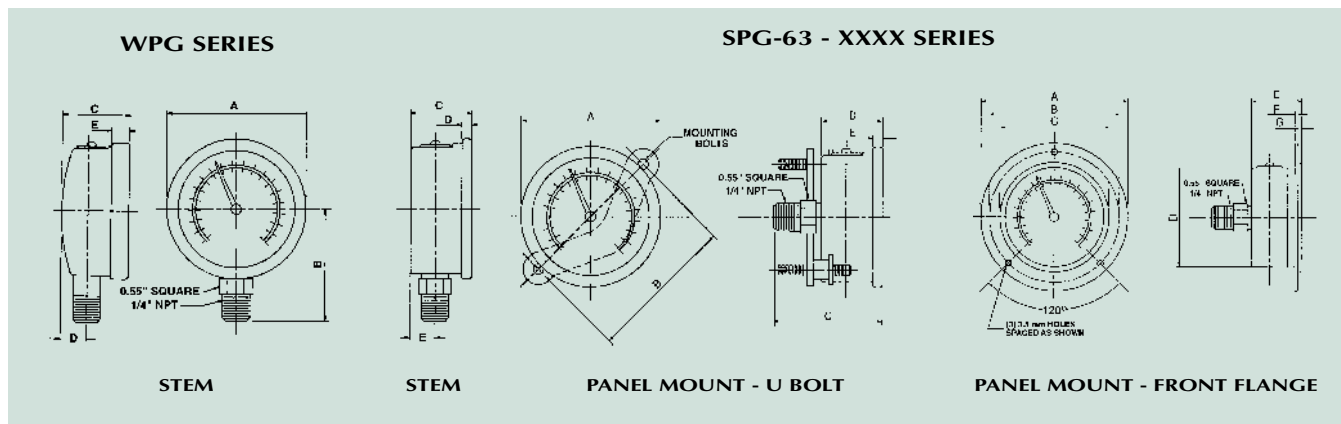

TEST

STANDARD STOCK PRESSURE RANGES

	SPG 63 SERIES STEM	SPG 63 SERIES PANEL	SPG 100 SERIES STEM	SPG 100 SERIES PANEL	WPG 63 SERIES STEM
30" Hg - 0 psi	•	•			
15" Hg - 30 psi					•
30" Hg - 30 psi	•	•			
0 - 30 psi					•
0 - 60 psi	•	•			•
0 - 160 psi	•	•			•
0 - 300 psi	•	•	•	•	
0 - 600 psi	•	•	•	•	•
0 - 1000 psi	•	•	•	•	•
0 - 1500 psi	•	•	•	•	•
0 - 2000 psi	•	•	•	•	•
0 - 3000 psi	•	•	•	•	•
0 - 5000 psi	•	•	•	•	•
0 - 6000 psi					•
0 - 7500 psi					•
0 - 10000 psi	•	•	•	•	

SERIES	STYLE	SIZE	SIZE								
			A	B	C	D	E	F	G		
SPG	STEM MOUNT	2 1/2"	in mm	2.5 63	2.1 53	1.2 31	0.51 13	0.26 6.5	-	-	
	PANEL MOUNT U-BOLT	2 1/2"	in mm	2.5 63	2.8 72	2.4 62	1.2 31	0.26 6.5	-	-	
	PANEL MOUNT FRONT FLANGE	2 1/2"	in mm	3.3 85	2.9 75	2.5 63	2.44 62	1.2 31	0.08 2	0.08 2	
	STEM MOUNT	4"	in mm	4.2 107	3.4 86	1.85 47	0.3 7.5	0.64 16.3	-	-	
	PANEL MOUNT U-BOLT	4"	in mm	4.2 107	4.25 108	3.15 80	1.85 47	0.3 7.5	-	-	
	PANEL MOUNT FRONT FLANGE	2 1/2"	in mm	5.2 132	4.7 118	4.2 107	3.15 80	1.85 47	0.05 1.25	0.3 7.5	
	WPG	STEM MOUNT	2 1/2"	in mm	2.5 63.5	2.13 54	1.5 38	0.44 11	0.50 12.2	-	-

ORDERING INFORMATION

SPG		63		1500		S		-	
CASE TYPE				PRESSURE RANGE		ORDER CODE		ATTACHMENT	
SPG - STAINLESS STEEL				-30" HG-30		3030		- NONE	
WPG - FORGED BRONZE				0-30		0030		U U - BOLT	
				0-60		0060		FF FRONT FLANGE	
				0-160*		0160			
				0-300		0300			
				0-600*		0600			
				0-1000*		1000			
				0-1500*		1500			
				0-2000*		2000			
				0-3000*		3000			
				0-5000*		5000			
				0-6000		6000			
				0-7500		7500			
				0-10,000		10000			
DIAL SIZE								MOUNTING	
63 - 2 1/2"								S STEM - NPT	
100 - 4"								P PANEL - NPT	
								SU STEM - 7/16-20 UNF	
								PU PANEL - 7/16-20 UNF	

* UNF only available in these ranges

ADJUSTABLE GAUGE FITTING EMV

Order No.	NBR	FPM	G ₁	G ₂	H	SW	Order No.	
							NBR	FPM
			G _{1/4}	G _{1/4}	42	19	EMV-G _{1/4} -P-OR-PC	EMV-G _{1/4} -V-OR-VC
			G _{1/4}	G _{1/2}	47	19	EMV-G _{1/4} /G _{1/2} -P-OR-PC	EMV-G _{1/4} /G _{1/2} -V-OR-VC
			G _{1/2}	G _{1/4}	51	27	EMV-G _{1/2} /G _{1/4} -P-OR-PC	EMV-G _{1/2} /G _{1/4} -V-OR-VC
			G _{1/2}	G _{1/2}	55,5	27	EMV-G _{1/2} -P-OR-PC	EMV-G _{1/2} -V-OR-VC

3/00

Complete Kits

TEST



Stauff-Test pressure monitoring kits are available pre-assembled with an assortment of our most popular components. everything required for instant pressure checking is included in one rugged box. Gauges are safely nestled in the Ethafoam® cushion and hoses fit neatly in the lid.

SINGLE GAUGE KIT A1

- | | |
|-----------------------------------|---------------------|
| 1 60 inch Hose Assembly | SMS20-060-A |
| 1 Direct Gauge Adaptor | SMD20-1/4 NPT-V |
| 1 Union | SSV20/20 |
| 1 7500 psi Gauge | WPG 7500-1/4 NPT-VD |
| 2 1/8 NPT Pressure Test Coupling | SMK20-1/8 NPT-VD |
| 3 1/4 NPT Pressure Test Coupling | SMK20-1/4 NPT-VD |
| 2 7/16 UNF Pressure Test Coupling | SMK20-7/16 UNF-VE |
| 2 9/16 UNF Pressure Test Coupling | SMK20-9/16 UNF-VE |



DOUBLE GAUGE KIT B1

- | | |
|-----------------------------------|-------------------|
| 1 60 inch Hose Assembly | SMS20-060-A |
| 2 Direct Gauge Adaptor | SMD20-1/4 NPT-V |
| 1 Union | SSV20/20 |
| 1 7500 psi Gauge | WPG 7500-1/4 NPT |
| 1 1000 psi Gauge | WPG 1000-1/4 NPT |
| 2 1/8 NPT Pressure Test Coupling | SMK20-1/8 NPT-VD |
| 2 1/4 NPT Pressure Test Coupling | SMK20-1/4 NPT-VD |
| 1 7/16 UNF Pressure Test Coupling | SMK20-7/16 UNF-VE |
| 1 9/16 UNF Pressure Test Coupling | SMK20-9/16 UNF-VE |



TRIPLE GAUGE KIT C1

- | | |
|-----------------------------------|-------------------|
| 2 60 inch Hose Assembly | SMS20-060-A |
| 3 Direct Gauge Adaptor | SMD20-1/4 NPT-V |
| 2 Union | SSV20/20 |
| 1 -15" Hg-0-30 psi Gauge | WPG 1530-1/4 NPT |
| 1 7500 psi Gauge | WPG 7500-1/4 NPT |
| 1 1000 psi Gauge | WPG 1000-1/4 NPT |
| 2 1/8 NPT Pressure Test Coupling | SMK20-1/8 NPT-VD |
| 2 1/4 NPT Pressure Test Coupling | SMK20-1/4 NPT-VD |
| 1 7/16 UNF Pressure Test Coupling | SMK20-7/16 UNF-VE |
| 1 9/16 UNF Pressure Test Coupling | SMK20-9/16 UNF-VE |

Custom Kits are easily supplied tailor made to your specific needs. OEMs in particular find this convenient for factory – trained technicians and as an aftermarket service tool. Custom labels, foaminserts and boxes are available in quantity.

TECHNICAL DATA FOR TEST-HOSES

Ordering code		A	B	C	
Nominal bore (DN)	(mm)	DN 2	DN 2	DN 4	
max. working pressure (PN)	Psi/(bar)	6000 (400)	9100 (630)	4900 (340)	
min. bursting pressure	Psi/(bar)	15,950 (1100)	27,550 (1900)	12,325 (850)	
Testing pressure	Psi/(bar)	8700 (600)	13,775 (950)	8265 (570)	
Pressure rating in bar at indicated temperature	at 0° C	Psi/(bar)	6500 (488)	11,136 (768)	6713 (463)
	at 30° C	Psi/(bar)	6380 (440)	10,048 (693)	6061 (418)
	at 50° C	Psi/(bar)	5800 (400)	9138 (630)	5510 (380)
	at 80° C	Psi/(bar)	4988 (344)	7859 (542)	4741 (327)
	at 100° C	Psi/(bar)	446 (308)	7032 (485)	4248 (293)
Working temperature	°F (°C)	-31° F ... 212° F (-35° C ... 100° C)			
Inside diameter	inch (mm)	0.08" (2)	0.08" (2)	0.16" (4)	
Outside diameter	inch (mm)	0.2" (5)	0.2" (5)	0.34" (8,6)	
Bending radius	at working pressure	inch (mm)	0.79" (20)	0.79" (20)	1.57" (40)
	at -20° C	inch (mm)	1.18" (30)	1.18" (30)	2.36" (60)
max. coil length	ft. (m)	325' (100)	325' (100)	325' (100)	
Weight/m	oz. (g)	0.5 (16)	0.5 (16)	1.35 (42)	
Inner/outer tube		PA	PA	PA	
Reinforcement		Synthetic fiber	Synthetic fiber	Synthetic fiber	

Hose ends made of 9S Mn Pb 28 (1.0718), zinc plated and chromated

Stainless steel on request

ORDERING CODE

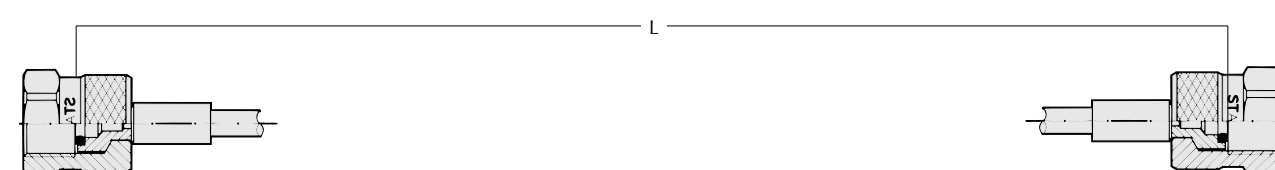

SMS — **20**

Hose End 1 (see Type page 74 - 77)		
20	A	J
15	S	D
12	K	B
10	L	U
M	G	P
N	F	
W	C	

/ M . . .

Hose End 2 (see Type page 74 - 77)

only specify when
2 different hose ends
are required

24

Length

Length inches (mm)
(see L above)

A

Nominal bore

A = DN 2 400 bar – 6000 Psi
 B = DN 2 630 bar – 9100 Psi
 C = DN 4 340 bar – 4900 Psi

3/00

TEST

Description	Hose end	Type	G	SW		DN	
				mm	in		
STAUFF-TEST Screw-type Suitable for test points		20	M16 x 2			2 and 4	
		15	M16 x 1,5				
		12	S 12,65 x 1,5				
STAUFF-TEST Screw-type 90° elbow Suitable for test points		O	20	M16 x 2			2
			15	M16 x 1,5			
			12	S 12,65 x 1,5			
STAUFF-TEST Plug in-type			10	Plug in system			2
Gauge adapter BSP-thread for G ³ / ₈ and G ¹ / ₂ BSP is similar to swivel nut type N		M	1/4	G ¹ / ₄	19	0.75	2 and 4
			1/2	G ¹ / ₂	27	1.06	
			3/8	G ³ / ₈	22	0.87	2
90° elbow gauge adapter BSP-thread for G ³ / ₈ and G ¹ / ₂ is similar to swivel nut type N		W	1/4	G ¹ / ₄	19	0.75	2 and 4
			1/4	G ¹ / ₄	27	1.06	
			1/2	G ¹ / ₂			
Gauge adapter NPT-thread for 1/4 NPT is similar to swivel nut type M		N	1/4	1/4 NPT	19	0.75	2
			1/2	1/2 NPT	27	1.06	

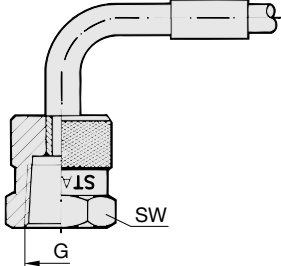
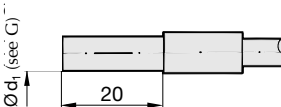
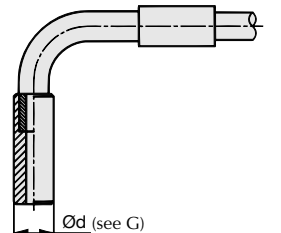
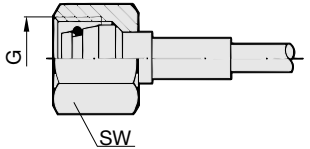
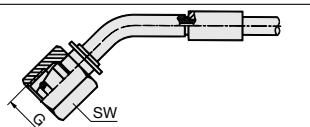
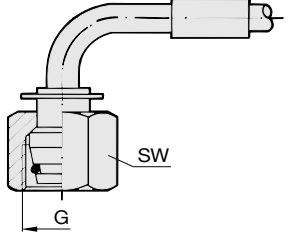
Description	Hose end	Type	G	SW		DN	
				mm	in		
90° elbow gauge adapter NPT-thread for 1/4 NPT swivel nut like type M		A	1/4	1/4 NPT	19	0.75	2 and 4
			1/2	1/2 NPT	27	1.06	
Standpipe according to DIN 2353		S	4	4 LL			2
			6	6 L – 6 S			2/4
			8	8 L – 8 S			2/4
			10	10 L – 10 S			2/4
			12	12 L – 12 S			2
			15	15 L			2
			1/4	1/4 0			2/4
Standpipe according to DIN 2353 90° elbow		on request				2 and 4	
Seal with O-ring for 24° cone fitting according to DIN 2353 c/w swivel nut		K	6 LL	M10 x 1,0	12	0.47	4
			6 L	M12 x 1,5	14	0.55	2/4
			8 L	M14 x 1,5	17	0.67	2/4
			10 L	M16 x 1,5	19	0.75	2/4
			12 L	M18 x 1,5	22	0.87	2/4
			6 S	M14 x 1,5	17	0.67	2/4
			8 S	M16 x 1,5	19	0.75	2/4
			10 S	M18 x 1,5	22	0.87	2/4
			12 S	M20 x 1,5	24	0.94	2/4
Seal with O-ring for 24° cone fitting according to DIN 2353 c/w swivel nut 45° elbow		R	6 S	M14 x 1,5	17	0.67	
Seal with O-ring for 24° cone fitting according to DIN 2353 c/w swivel nut 90° elbow		L	6 L	M12 x 1,5	14	0.55	2 and 4
			8 L	M14 x 1,5	17	0.67	
			10 L	M16 x 1,5	19	0.75	
			6 S	M14 x 1,5	17	0.67	
			8 S	M16 x 1,5	19	0.75	
			10 S	M18 x 1,5	24	0.95	

3/00

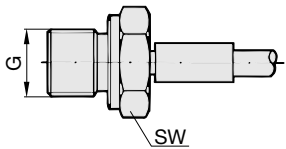
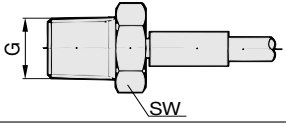
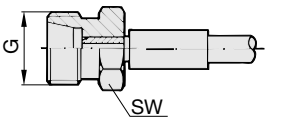
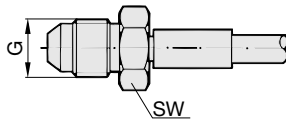
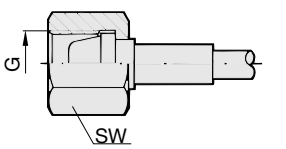
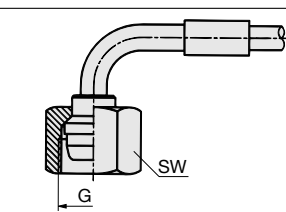
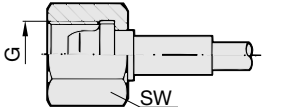
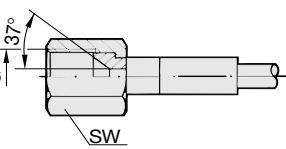
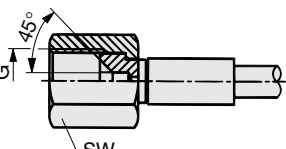
Description	Hose end	Type	G	SW		DN	
				mm	in		
Male thread according to DIN 3852		G	12	M12 x 1,5	17	0.67	2 and 4
			1/8	G 1/8	14	0.55	
			1/4	G 1/4	19	0.75	
			1/2	G 1/2	27	1.06	
Male thread NPT according to ANSI-Norm		F	1/8	1/8 NPT	13	0.51	
			1/4	1/4 NPT	17	0.67	
Male thread for 24° cone fitting according to DIN 3852		C	6 L	M12 x 1,5	14	0.55	
			8 L	M14 x 1,5	17	0.67	
			6 S	M14 x 1,5	17	0.67	
			8 S	M16 x 1,5	17	0.67	
Male thread according to SAE J 514		J	1/4	7/16 - UNF	14	0.55	
			5/16	1/2 - UNF	14	0.55	
			3/8	9/16 - UNF	17	0.67	
Universal sealing head with swivel nut for 24° cone fitting according to DIN 2353		D	6 L	M12 x 1,5	14	0.55	
			8 L	M14 x 1,5	17	0.67	
			10 L	M16 x 1,5	19	0.75	
			12 L	M18 x 1,5	22	0.87	
			6 S	M14 x 1,5	17	0.67	
			8 S	M16 x 1,5	19	0.75	
			10 S	M18 x 1,5	22	0.87	
			12 S	M20 x 1,5	24	0.94	
Universal sealing head with swivel nut for 24° cone fitting according to DIN 2353 90° elbow		Q	10 L	M16 x 1,5	19	0.75	
			10 S	M18 x 1,5	22	0.87	
Sealing head with swivel nut for cone fitting according to DIN 8542		B	1/4	G 1/4	17	0.67	
Sealing head with swivel nut according to SAE J 514 37° cone		U	1/4	7/16 - 20 UNF	14	0.55	
			5/16	1/2 - 20 UNF	17	0.67	
			3/8	9/16 - 18 UNF	19	0.75	
Sealing head with swivel nut according to SAE J 514 f 45° cone		UR	1/4	7/16 - 20 UNF	14	0.55	2

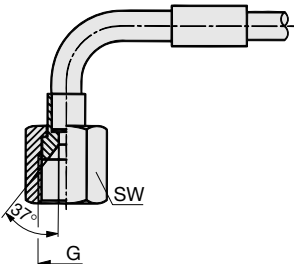
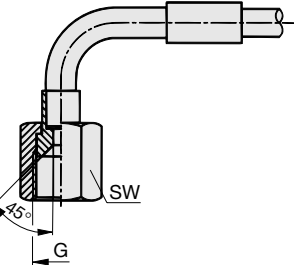
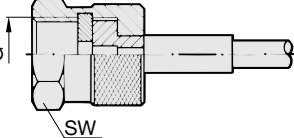
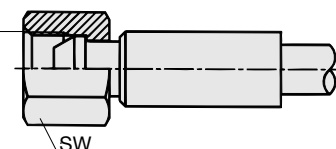
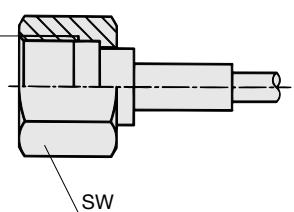
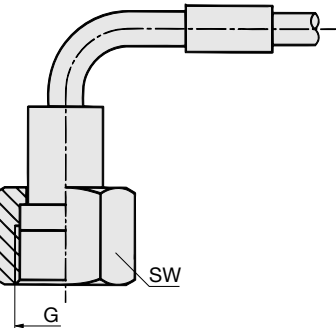
Description	Hose end	Type	G	SW		DN	
				mm	in		
Sealing head with swivel nut according to SAE J 514 37° cone 90° elbow		E	1/4	7/16 - 20 UNF	14	0.55	2
Sealing head with swivel nut according to SAE J 514 f 45° cone 90° elbow		ER	1/4	7/16 - 20 UNF	14	0.55	2
Test hose for air brake systems		P	2	M 16 x 1,5	19	0.75	
Sealing head with swivel nut 60° cone		H	1/4	G 1/4	17	0.67	4
Screw-type ORS according to SAE J 1453		T	11/16	11/16 - 16 UN	21	0.83	2
Screw-type ORS according to SAE J 1453 90° elbow		V	11/16	11/16 - 16 UN	21	0.83	2 and 4

3/00

TEST

HAND-HELD MEASURING UNIT IDEAL FOR MAINTENANCE, SERVICE AND COMMISSIONING OF HYDRAULIC SYSTEMS

Today's hydraulic systems require a precise, quick and uncomplicated way of measuring important hydraulic parameters. For this purpose STAUFF offers the ideal solution: The PPC 04.

The mobile measuring device PPC 04 is controlled by its 8 buttons enabling the user of the device to easily obtain data on working pressure, peak pressure, differential pressure, temperature, flow and rotational speed. This results in a wide range of applications in the areas of:

- Industrial Hydraulics
- Mobile and Agricultural Hydraulics
- Marine and Offshore Hydraulics
- Chemical and Petrochemical Industry
- Energy and Aircondition Industry
- Sanitary Industry

The PPC 04 provides two separate sensor inputs which automatically recognize the sensors connected to it and displays the unit and scale for the corresponding sensor. The unit and scale can be changed during use.

Data can be output to the optional Thermo-Printer or a PC using the appropriate cables and adaptors.

The PPC04 is insensitive to dirt and is designed to be used wherever hydraulic control and components are in use. The heavy duty rubber cover protects the unit from damage during use in extreme conditions. The PPC04 is powered either by a standard 9v battery (PPC04 B), or by an integrated rechargeable battery (PPC04 AP). Operation for an extended period of time is supported with the use of the AC power adaptor.

Note! Not all output features are supported by the non-rechargeable unit (PPC04 B).

PPC04 Kits are supplied complete with adaptors to connect the unit to Stauff Test 20/15/12 and Stauff Test 10 test points, even under pressure. Temperature and Flow measurement is possible using Temperature Sensor TS04 or SFM flow turbines mounted in the hydraulic line. Rotational speed can be measured using the Stauff SDS-04 rotational speed sensor.

In order to measure differential pressure two transducers of the same pressure range have to be used.

EMC compatibility acc. to:
 Interference emission DIN/EN 50081-1 (VDE 0839 part 81-1)
 Resistance to jamming DIN/EN 50082-2 (DVE 0839 part 82-6)

HAND-HELD UNIT PPC 04 - B AND PPC 04 - AP

Measures:

- Pressure in bar and psi
- Temperature in °C and °F
- Flow in l/min and GPM (US)
- Rotational speed in RPM

PPC 04 - AP hand-held unit with rechargeable battery and data output

- 4-digit LCD-display, character height: 13 mm
- Automatic recognition of sensors connected
- Optical data transmission to transfer values measured to thermoprinter or PC (PPC 04 - AP only)
- Plastic housing made of ABS Protective rubber cover with integrated stand and carrying straps
- Auto power off after 15 minutes (except autoprint function)

Power supply:

9 V block battery IEC 6F 22 (PPC 04 - B)
 Rechargeable battery - or by external power supply
 Supply voltage 9 V (PPC 04 - AP)

12-bit-A/D-converter

Scanning rate ≤ 2 ms

Accuracy < 0,3%± 2 Digit

Two 4-pin round plug inputs 0, 1...3,3 V, RE = 470 kΩ

Temperature range 0...+50°C 32°F...122°F

Storage Temperature -20...+60°C -4°F...140°F

Rel. Humidity < 85%

Dimensions l/w/h 145 x 70 x 40mm 5.7" x 2.75" x 1.57"

Weight approx. 340 g 0.75 lbs.

Protection level DIN 40050/IP 54



3/00

PRESSURE TRANSDUCER PTD

Type	PTD 015	PTD 063	PTD 630
Pressure range	-15...210 psi -1...15 bar	0...900 psi 0...63 bar	0...9000 psi 0...630 bar
Overload capacity	290 psi 20 bar	2175 psi 150 bar	14,500 psi 1000 bar
Burst pressure	650 psi 45 bar	7250 psi 500 bar	26,000 psi 1800 bar
Output signal	+0,1...+3,3 V	+0,3...+3,3 V	+0,3...+3,3 V
Reproducibility	<±0, 15% FS*	<±0, 18% FS*	<±0, 15% FS*

Test system piezoresistive
 Temperature deviation <±0,03 % FS*
 Characteristic curve deviation <±0,5 % FS*
 Long-time stability <0,5 % FS/a
 Response time < 1 ms
 Vibration resistance IEC 68-2-6 AT 10...500 Hz
 Max. shock-load to IEC 68 part 2 to 29
 Peak pressure increase 21,000psi/sec 15,000 bar/s
 Supply voltage +7V...+15V DC
 Current consumption ≤ 5 mA
 Media-temperature range -13...221°F -25...+105°C
 Ambient temperature range -4...185°F -20...+85°C
 Compensated temperature range 32...185°F 0...+85°C
 Storage temperature range -40...257°F -40...+125°C
 Endurance 10 Million cycles
 Media application gas, fluids (for use with aggressive media please consult STAUFF) with adapter STAUFF Test

Transducer connection 20 (M16 x 2) (without adapter G 1/2 A)
 Material of housing stainless steel 1.4301
 Sealing material FPM
 Weight approx. 200 g (0.44 lbs.)
 Protection level DIN 40050 - IP 65
 78" (2 mtr.) -cable connected with transducer, round plug series 712

* FS = Full Scale

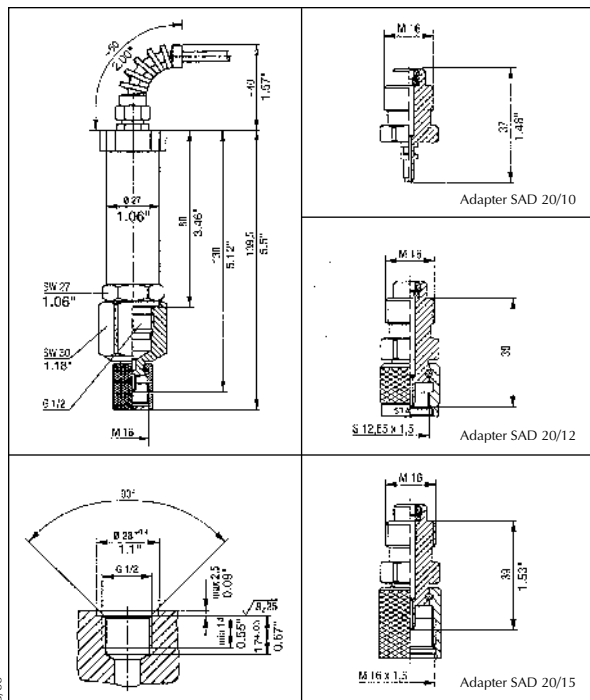

TEMPERATURE SENSOR TS 04

Probe system Silicon Chip
 Measuring range -13...257°F -25...+125°C
 Accuracy ± 1.5 % FS*
 Response time T 0,9 approx. 7 s
 Supply voltage +7...+15 V DC
 Current consumption ≤ 3 mA
 Outage voltage +0,25...+1,75 V
 Max. working pressure 9000psi 630 bar
 Ambient temperature range 32...158°F 0...+70°C
 Media-temperature range -13...257°F -25...+125°C
 Storage temperature range -13...176°F -25...+80°C
 Cable length 78" (2m), round plug
 Sensor connection a) STAUFF-Test-straight fitting SGV-16-S-G for in-line installation
 b) Port Connection M10 x 1
 Material Steel 9SMnPb28k
 Surface treatment zinc plated, yellow chromated
 Sealing FPM
 Protection level DIN 40050 - IP 65

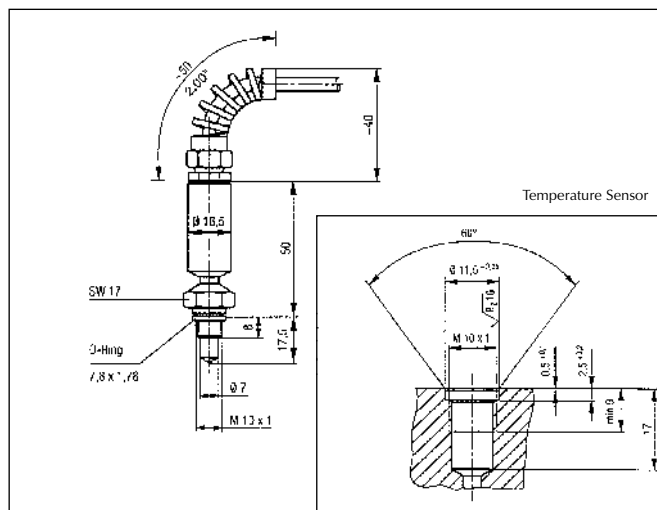
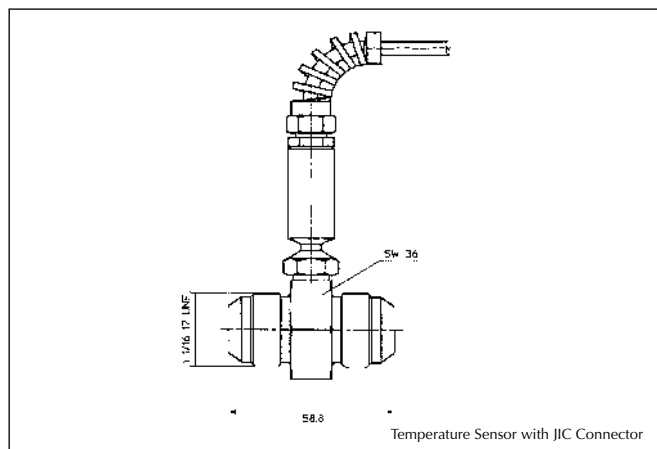

FLOW-TURBINES SFM

Type		SFM-015	SFM-060	SFM-300	SFM-600
Measuring range	(GPM)	0.26-3.9	1.95-15.6	3.9-78	7.8-156
	(LPM)	1-15	7.5-60	15-300	25-600
Pressure range	(PSI)	5800	5800	5800	5800
	(Bar)	400	400	400	350
Characteristic curve deviation (≤%FS)		1	1	1	1
Pressure drop	(PSI)	2.03			
	(Bar)	0.14	0.28	2.0	1.7
Port Connection (BSP)	G	1/2"	3/4"	1"	1 1/4"
Port Connection (SAE)	G	3/4"-16	1 1/16"-12	1 5/16"-12	1 5/8"-12
Weight		1.4 lbs.	1.6 lbs.	2.6 lbs.	4 lbs.

Media-temperature range -4...302°F -20...+150°C
 Response time approx. 200 ms
 Reproducibility ± 0,2 % Full Scale
 Calibration viscosity 30 mm 2/s (+30 cST)
 Material of housing Aluminum
 Surface treatment black anodized
 Test point SMK 20 (M16 x 2)
 Additional connection M10x1 (standard): screw-plug

DIM	SIZE	SFM-015	SFM-060	SFM-300	SFM-600
		A	in 0.88 mm 22.5	in 1.04 mm 26.5	in 1.20 mm 30.5
B	in 1.24 mm 31.5	in 1.50 mm 38	in 1.97 mm 50	in 2.46 mm 62.5	
D	in 2.3 mm 58.5	in 2.26 mm 57.5	in 2.26 mm 57.5	in 2.26 mm 57.5	
L	in 4.72 mm 120	in 5.08 mm 129	in 5.86 mm 149	in 6.81 mm 173	
H	in 1.47 mm 37.5	in 1.81 mm 46	in 2.20 mm 56	in 2.5 mm 63.5	

SIGNAL CONVERTER

To be used when using flow-turbines in conjunction with PPC 04. (Signal converter is supplied with the flow turbine)

Input 10...2000 Hz, 10...100 mVss
 Output 0...3 V and sensor recognition
 Accuracy ≤ 0,3 % Full Scale
 Response time approx. 200 ms
 Working temperature 0...+60°C 32...140°F
 Storage Temperature -20...+80°C -4...176°F
 Supply voltage +7...+15 V DC
 Current consumption approx. 8 mA
 Electrical connection Turbine end:

cable 16" (0.4 m) connected to signal converter with 5 pin plug connection to hand-held unit: cable SFM 78" (2m)
 Material of housing stainless steel 1.4301
 Weight approx. 200 g (0.44 lbs.)

SIGNAL CONVERTER

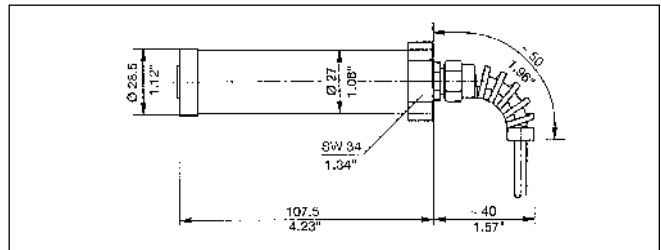

NOTE: The flow turbine and the signal converter are matched units.

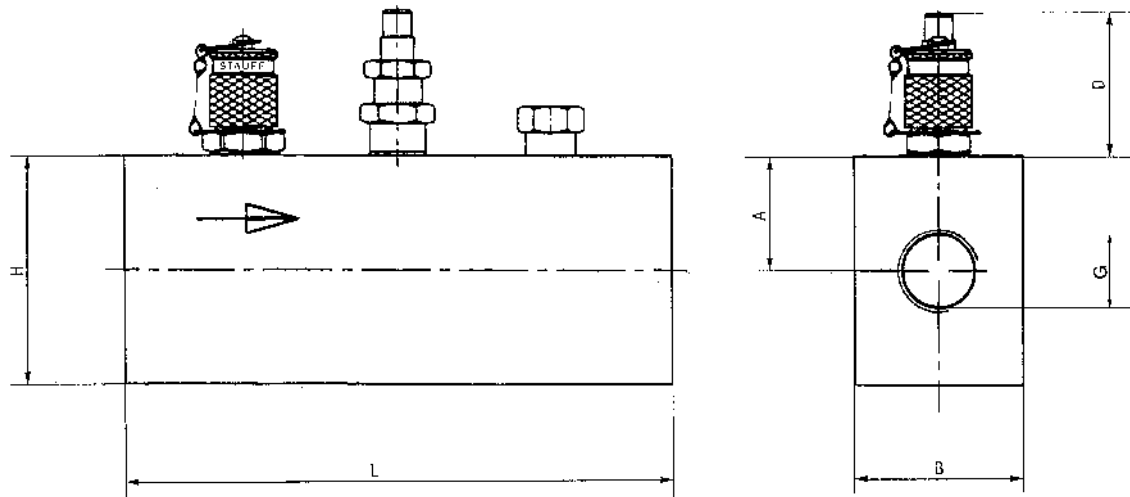

3/00

TEST

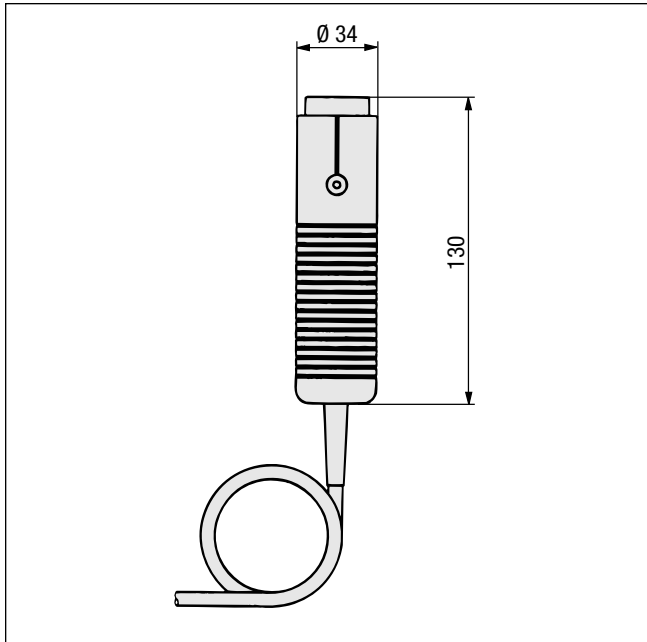

ROTATIONAL SPEED SENSOR SDS-04

Rotational speed measurement (RPM) is made possible with the use of the SDS 04 non-contact sensor. Speed measured using a photoelectric cell which counts revolutions via a reflecting strip or marking on the rotating surface resulting in a high level of accuracy.

Additionally a contact sensor is available. A mechanical contact adaptor is connected to the speed sensor, which is held onto the rotating surface during measurement.

When used with particularly small surfaces, accuracy may be improved by using a special focusing adaptor.

Lengthening of the SVK 04 cable could result in inaccurate speed measurement and should be avoided. The standard cable length of 3 m, fixed to the sensor should not be altered for best results.

TECHNICAL DATA

Input

Measuring range 20...10.000 RPM
 Measuring distance 25...600 mm (1"-24")
 Measuring angle $\pm 45^\circ$
 Measurement optical, red LED

Output

Output signal 0...3 V DC=0...10.000 RPM
 Accuracy <0.5%
 Resolution ± 5 RPM
 Supply voltage 7...9 V DC (of the PPC 04)

Electrical connection

Cable connected to the sensor length 3 m, round plug (extension cable not recommended)

General

Material ABS
 Dimension D= \varnothing 34 (1.34"), L=130 mm (5.1") (without adaptor)
 Weight approx. 230 g (0.5 lb.)

ACCESSORIES

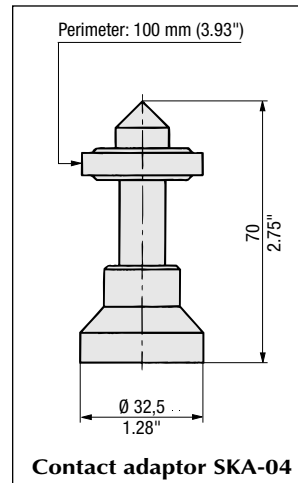

Contact adaptor SKA-04

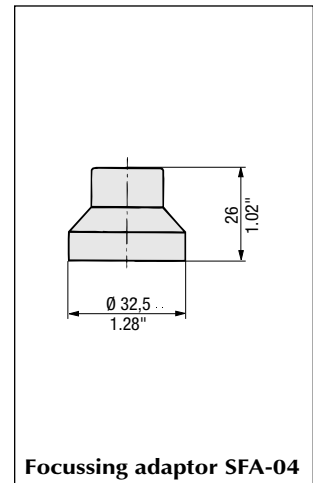

Focussing adaptor SFA-04

APPLICATIONS

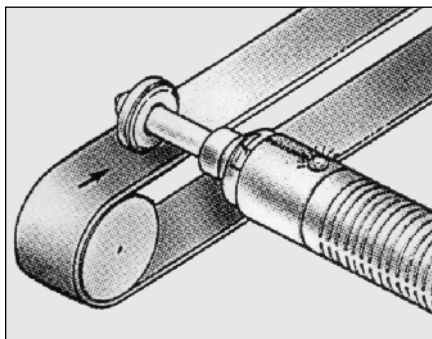

App. 1 – rotating shaft non-contact RPM

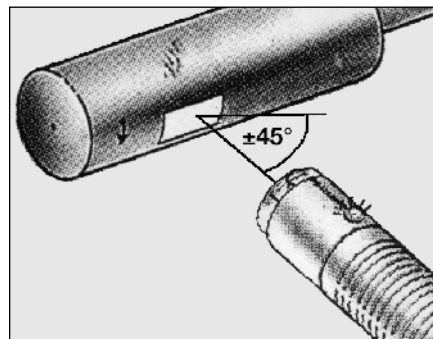

App. 2 – RPM with contact adaptor using perimeter

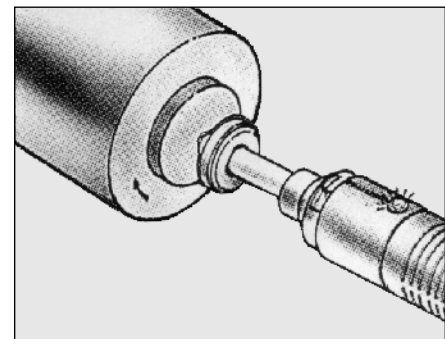

App. 3 – RPM with contact adaptor using point

3/00

THERMOPRINTER PR PPC (FOR PPC 04 - AP ONLY)

The thermoprinter PR PPC provides the possibility to record most of the important hydraulic parameters like maximum, minimum and current values, following a preset transmission interval from 1 to 100 seconds.

The power-off mode of the PPC 04 is disabled during long-periods of measurement. The thermoprinter PR PPC is powered by an external power supply KNG PR PPC to which the PPC 04 - AP can be connected as well.

All data measured by the PPC 04 AP is transferred by a dirt-insensitive optical data transmission in conjunction with a fiber optic cable supplied with the printer.

PC-CONNECTION (PPC 04 - AP)

The PPC 04 - AP can also be connected to any PC by using the fiber optic cable (SDK - 04) and an auxiliary adapter (SPA - 04). Standard software installed on most computers is suitable to evaluate data transferred.

PRINTER PR PPC



PPC 04 COMPLETE KITS

PPC 04 kits are supplied with a plastic case including foam inserts which provides room for the following components:

- 1 hand-held unit
- 1 external power supply
- 3 pressure transducers c/w STAUFF Test 20 adapters
- 1 temperature sensor with straight fitting SGV-16 S-G
- 3 adapters for STAUFF Test 15 / 12 / 10 (are supplied with each PPC 04 kit)

Kits can be tailored according to customer requirements.



3/00

TEST

ORDER CODE FOR PPC 04 KITS

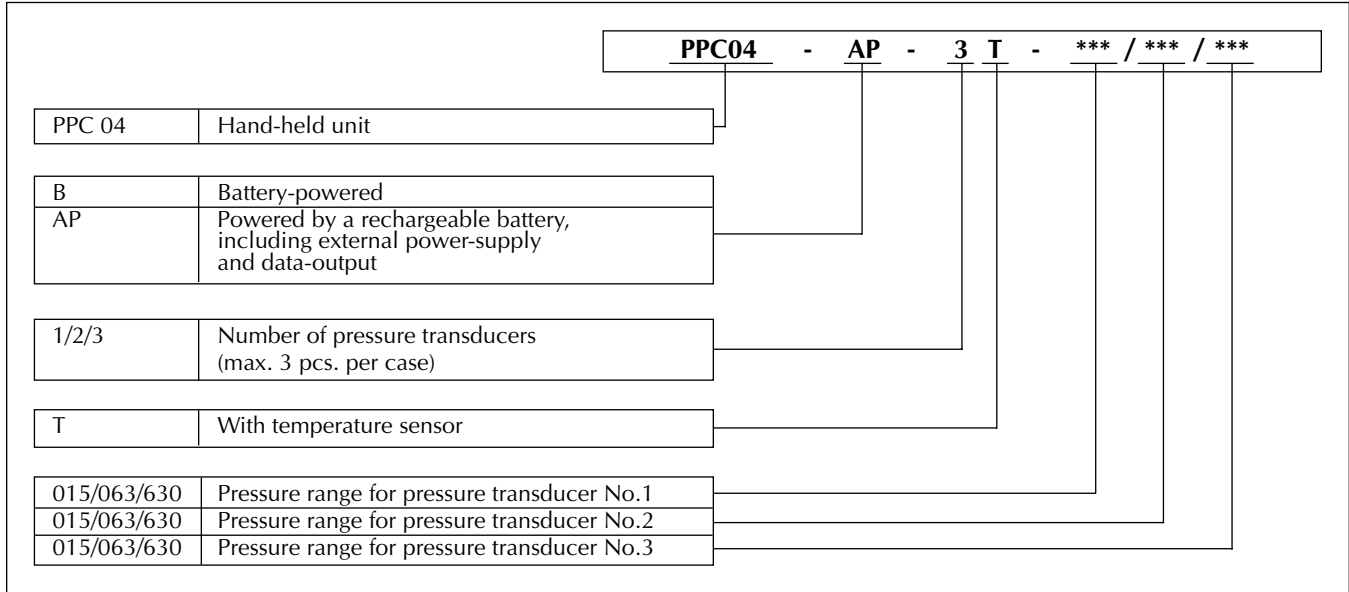

In order to measure differential pressure two (2) transducers of the same pressure have to be used.

COMPONENTS

Description	Order Code
Hand-held unit with block battery	HAG PPC 04 - B
Hand-held unit with rechargeable battery and data output	HAG PPC 04 - AP
External power supply ... input voltage 220 V or 110 V	KNG 04 - *** V
Rechargeable battery for PPC 04 - AP	Akku - 9V
Pressure transducer connection G 1/2 A	PTD ***
*** = pressure range 015,063 or 630 (bar)	
Pressure transducer c/w STAUFF Test 20 adapter	PTD *** -SDA
*** = pressure range 015, 063 or 630 (bar)	
STAUFF Test 20 adapter for pressure transducer	SDA 20 - G 1/2
STAUFF Test 20 / STAUFF Test 15 adapter	SAD 20/15 - P
STAUFF Test 20 / STAUFF Test 12 adapter	SAD 20/12 - P
STAUFF Test 20 / STAUFF Test 10 adapter	SAD 20/10 - P
Temperature sensor (w/o straight fitting)	TS 04
Straight fitting 16 S with M 10 x 1 port connection for temp. sensor	SGV - 16S - G
(Other dimensions on request)	
Plastic case c/w foam inserts	case PPC 04
Flow-turbine c/w signal converter	SFM - ***
*** = flow rate 015, 060, 300 or 600 (l/min)	
Connecting cable PPC 04 - signal converter	cable SFM -04
Thermoprinter	PR PPC
External power supply for thermoprinter PR PPC (110 V / 220 V change-over switch)	KNG PR PPC
Glassfiber cable PPC 04 - thermoprinter / PC	SDK - 04
PC-adapter to connect glassfiber cable to PC	SPA - 04
Paper for thermoprinter PR PPC	SPR PR PPC
Plastic case with foam inserts	case PR PPC

Because of technical advances, data given is subject to change without notification

PRESSURE TRANSMITTERS

OEM PRESSURE TRANSMITTERS

TYPE 891.24.540 RANGES 300 PSI TO 15,000PSI

STAUFF pressure transmitters are specifically designed to meet price and performance requirements of Original Equipment Manufacturers. The SPT pressure transmitters use a thin film sensor for pressure ranges 300 PSI to 15,000 PSI.

The model features a highly stable, temperature compensated, conditioned output signal. As an option for additional reliability, 3-wire voltage current output circuits are protected from electromagnetic interference as specified by international standard IEC 801.

With a stainless steel case and compact design, STAUFF SPT pressure transmitters provide a high performance sensor package featuring excellent vibration resistance and long service life. OEM applications include hydraulics, pneumatics HVAC compressor control, machine tools, robotics and off road equipment.

Note: * Maximum pressure, causing no permanent changes in specifications but may lead to zero and span shifts.
 ** Burst pressure, leading to permanent changes in specifications (i.e. zero offsets) or destruction of the transmitter.

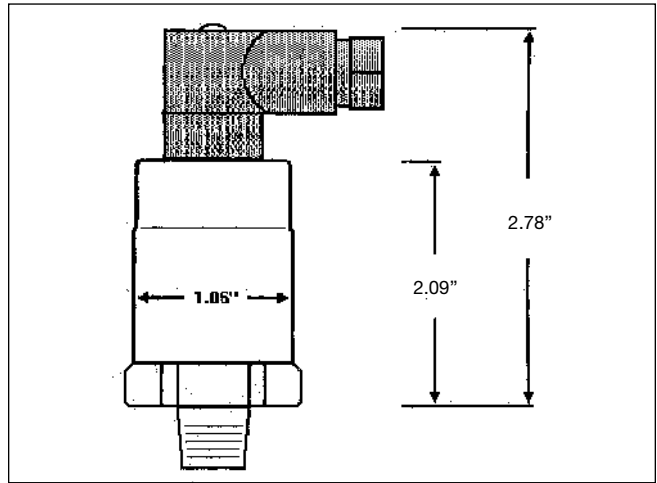

ORDERING CODES

SPT-XXXX-N04-420-MD

- SPT:** Stauff Pressure Transmitter
- XXXX:** Pressure Range
- N04:** 1/4" NPT – B04: 1/4" BSP – S: SAE 7/16-20
- 420:** 4-20mA Output 2-wire
- MD:** Mini DIN Plug

Example:
SPT-1500-N04-420-MD

STANDARD RANGES MODEL SPT SERIES*

Range	Maximum	Burst**
0-300 PSIG	725 PSI	3625 PSI
0-400 PSIG	725 PSI	3625 PSI
0-500 PSIG	1160 PSI	5800 PSI
0-600 PSIG	1160 PSI	5800 PSI
0-1000 PSIG	1740 PSI	7975 PSI
0-1500 PSIG	2900 PSI	11,600 PSI
0-2000 PSIG	2900 PSI	11,600 PSI
0-3000 PSIG	7250 PSI	17,400 PSI
0-5000 PSIG	11,600 PSI	24,650 PSI
0-7500 PSIG	17,400 PSI	34,800 PSI
0-10,000 PSIG	17,400 PSI	34,800 PSI
0-15,000 PSIG	21,750 PSI	43,500 PSI

Note: * Shaded ranges are stock

3/00